

# REMOTE CONTROLLED MOWER SPIDER



## OPERATOR'S MANUAL

SPIDER CROSS LINER and SPIDER CROSS LINER LITE

Revision 4 \_ 2021

S.N. 185 -



Product's production number	
Engine type	
Engine's production number	

**DVOŘÁK – svahové sekačky s.r.o.**

Pohled 277, 582 21 Pohled, Czech Republic

+420 564 036 099, [info@spider-cz.com](mailto:info@spider-cz.com), [www.spidermower.com](http://www.spidermower.com)

Notes:

# TABLE OF CONTENT

<b>INTRODUCTION</b>	<b>5</b>
<b>1 INSTRUCTIONS</b>	<b>6</b>
<b>2 EC/EU DECLARATION OF CONFORMITY</b>	<b>7</b>
<b>3 SAFETY</b>	<b>8</b>
3.1 SAFETY WARNINGS.....	8
3.2 SAFETY INSTRUCTIONS.....	9
3.3 SAFETY LABELS .....	11
<b>4 ABOUT THE PRODUCT</b>	<b>14</b>
4.1 MAIN COMPONENT LOCATION.....	14
4.2 USE OF THE MOWER.....	15
4.3 MAXIMUM SLOPE INCLINE .....	15
4.4 PROHIBITED USE .....	16
4.5 HAZARDOUS ZONE .....	16
4.6 REMOTE CONTROLLER (RC).....	17
4.7 CONTROL UNIT AND WIRING HARNESS .....	19
<b>5 OPERATION</b>	<b>21</b>
5.1 MOWER SAFETY INSPECTION .....	21
5.2 STARTING THE ENGINE .....	22
5.3 STOPPING AND PARKING .....	23
5.4 DRIVING THE MACHINE.....	24
5.5 CUTTING BLADE ON/OFF .....	25
5.6 MOWING HEIGHT ADJUSTMENT .....	26
5.7 DRIVING ON SLOPES.....	26
5.8 HYDRAULIC STABILIZING WINCH* .....	27
<b>6 STORAGE</b>	<b>31</b>
6.1 CLEANING .....	31
6.2 STORAGE .....	31
6.3 REFUELING THE MACHINE .....	32
<b>7 MOWER TRANSPORTATION</b>	<b>32</b>
<b>8 MAINTENANCE</b>	<b>33</b>
8.1 MAINTENANCE SAFETY .....	33
8.2 MAINTENANCE SCHEDULE.....	34
8.3 MOWER SERVICE POSITIONS.....	36
8.4 SERVICE POINTS .....	38
8.5 GEOMETRY ADJUSTMENT.....	40
8.6 ENGINE MAINTENANCE.....	42
8.7 FUEL SYSTÉM.....	45
8.8 MOWING BLADE .....	46
8.9 HYDRAULIC SYSTEM.....	47
8.10 HYDRAULIC STABILIZING WINCH* .....	47
8.11 ELECTRICAL SYSTEM.....	48
8.12 NEUTRAL POSITION ADJUSTMENT .....	52
8.13 DRIVE BELTS AND STERING CHAINS.....	53
8.14 WHEEL PORTALS .....	55
8.15 LUBRICATION .....	55
8.16 TYRE PRESSURE .....	55
8.17 TYRE REPLACEMENT .....	55
8.18 MOWING HEIGHT ADJUSTMENT .....	56

<b>9</b>	<b>TECHNICAL DATA</b>	<b>57</b>
9.1	FLUIDS, LUBRICANTS AND FILLING VOLUMES.....	57
9.2	TECHNICAL DATA.....	57
<b>10</b>	<b>TROUBLESHOOTING</b>	<b>59</b>
10.1	MOWER TROUBLESHOOTING .....	59
10.2	WINCH TROUBLESHOOTING .....	60
10.3	REMOTE CONTROL TROUBLESHOOTING .....	60
<b>11</b>	<b>WARRANTY CONDITIONS</b>	<b>61</b>

# INTRODUCTION

## **OPERATING INSTRUCTIONS**

**This manual is an integral part of the mower, keep it clean and in good condition. In case of loss or damage, replace it immediately. Always keep it available with the machine and, if handed over to another owner/operator, please provide the manual as well.**

Read these operating instructions carefully, if you do not understand some point, contact your supplier or the manufacturer to clarify. Do not operate the mower without proper understanding of the operation manual.

Improper use, maintenance or operation may result in serious injury or even death or to you or others.

This machine is intended for mowing grass under normal conditions. Any other use is contrary to the intended use of the machine. Strict compliance with the conditions of use, maintenance and repair as prescribed by the manufacturer also forms an integral part of the intended use of the machine.

Accident prevention, occupational safety and health as well as all traffic rules and regulations must always be followed.

**The manufacturer disclaims any liability for modifications, changes made to the product that are not carried out and approved by the manufacturer, non-compliance with the instructions for use, as well as the consequences of damage to property or the health of the operator or other people.**

## **USED SYMBOLS**



Warns of a very likely risk of serious or life-threatening injury if the relevant instructions are not followed.



Provides helpful information.

# 1 INSTRUCTIONS

## SERIAL NUMBER

In this manual you will find information about the **SPIDER CROSS LINER** and **SPIDER CROSS LINER LITE**. Applies to all models starting with serial number 185.

## MANUFACTURER'S ADDRESS

DVOŘÁK – svahové sekačky, s.r.o.,  
Pohled 277  
582 21 Pohled, Czech Republic  
[www.spidermower.com](http://www.spidermower.com)

## MOWER DELIVERY

Before putting the mower into operation for the first time, each owner is obliged to ensure the proper technical and practical training of his staff - the operation and the basic maintenance of the mower. Training and practical training will be carried out by a sales representative - a product specialist, a service worker of the manufacturer or supplier of the mower when putting the mower into operation.

The training will be registered by the manufacturer's or distributor's / dealer's representative with a written record of all trained personnel. Trained staff must sign the protocol.

**Manufacturer representative is:**

## IDENTIFICATION OF COMPONENTS AND PRODUCT

### MOWER

The mower serial number is marked on the label located on the mower.

### ENGINE

Important engine information and serial number can be found on the rear of the engine block.



Engine name plate

Mower production label

## 2 EC/EU DECLARATION OF CONFORMITY

<b>Manufacturer:</b>	DVOŘÁK – svahové sekačky s.r.o.
<b>Address:</b>	Pohled 277, 582 21 Pohled, Czech Republic
<b>ID:</b>	26013797
<b>Name and address of the person authorised to compile the technical file (according to 2006/42/EC) and the name and address of the person who keeps the technical documentation (according to 2000/14 / EC, NV No. 9/2002 Coll.)</b>	Pavel Vondráček, DiS. DVOŘÁK – svahové sekačky s.r.o. Pohled 277, 582 21 Pohled, ČR
<b>Product (Machine) – Type:</b>	<b>Mower SPIDER CROSS LINER</b>
<b>Serial number:</b>	
<b>Description:</b>	SPIDER CROSS LINER is a remote-controlled mower designed for mowing and mulching grasslands on normal and sloping terrain.
<b>We declare that the machinery fulfils all the relevant provisions of the mentioned Directives (Government Provisions):</b>	Directive 2006/42/ES, NV č. 176/2008 Sb. Directive 2014/30/EU, NV č. 117/2016 Sb. Directive 2000/14/ES, NV č. 9/2002 Sb.
<b>The harmonized technical standards and the technical standards applied to the conformity assessment:</b>	ČSN EN ISO 12100, ČSN EN ISO 5395-1, ČSN EN ISO 5395-2, ČSN EN ISO 4413, ČSN EN ISO 13857, ČSN EN ISO 14982:2009, ČSN EN ISO 11201, ČSN EN ISO 3744.
<b>Persons participating conformity assessment:</b>	Notified Body No. 1016. The Government Testing Laboratory of Machines., Joint-stock company. Třanovského 622/11, 163 04 Praha 6–Řepy, Czech Republic
	Final Report No.: 38 223
<b>Used conformity assessment procedure:</b>	On the basis of Directive 2000/14/EC, Annex VIII.
<b>Measured sound power level:</b>	$L_{WA} = 95,8 \text{ dB}$
<b>Guaranteed sound power level:</b>	$L_{WA,G} = 98 \text{ dB}$

Note: All regulations were applied in wording of later amendments and modifications valid at the time of this declaration issue without any citation of them.

**Place and date of issue:**

Pohled, 3.6.2019

**Signed by the person entitled to deal in the name of producer:**

Lubomír Dvořák, MBA.

**Name:**

Lubomír Dvořák, MBA.

**Grade:**

CEO

**Signature:**



 **spider**®  
DVOŘÁK - svahové sekačky s.r.o.  
Pohled 277, 582 21 Pohled  
IČ: 26013797, DIČ: CZ26013797

## 3 SAFETY

Each mechanism is potentially dangerous. However, if you operate the product properly and keep it in good working condition, working with it will be completely safe. If you operate it carelessly or neglect the basic maintenance, it can be dangerous for you (the operator) as well as others.

You will find warnings in this manual and on the product, read them and follow them. The manual will alert you to potential hazards and advise you on how to avoid them. If you do not understand the warning messages, ask your employer or SPIDER distributor / dealer for an explanation.

Please be aware that security is not just a matter of responding to a given alert. You must keep in mind the possible hazards and try to avoid them for the duration of the work on or with the product.

**Do not start working with the mower until you are sure that you can operate it properly.**

Do not start working with the mower **until you are sure it is safe for you and others around you.**

If you are unclear about the product or work, ask someone who can properly inform you. Do not assume anything.

Safety instructions are provided in this manual and on the product. Each notification is indicated by a signal word.

The meanings of the signal words are given below.

The words: **'DANGER'**, **'WARNING'**, **'CAUTION'** are to be taken seriously. They indicate the likelihood of serious injury or danger to life if the relevant instructions are not followed.



**This safety symbol indicates important safety messages in this manual. When you see this symbol, be alert to the possibility of injury, carefully read the message that follows, and inform other operators.**

### 3.1 SAFETY WARNINGS

The mower is equipped with the following safety parameters:

Parameter	Normal value	Sound signalization	Automatic mower shutdown *
Mower angle of inclination	<40°	40°	72° (mowing blade automatic cut-off)
No radio signal after starting the mower		After 60 sec.	
Loss of radio signal during operation		After 10 sec.	
Control unit voltage	>11.5 V		<10.5 V

\* The mower and remote control must ALWAYS be switched off using the EMERGENCY STOP button on the mower and the main switch on the remote control.



## 3.2 SAFETY INSTRUCTIONS

- Do not enter or reach under the machine if it is lifted and not sufficiently supported. The machine should be supported on places marked by the symbol of a lifting jack.
- If the engine stops on a slope, it is necessary to secure the wheels against movement (for example with wooden wedges)
- The mower should only be transported in a container or on a trailer.
- Check bolt torques at regular intervals. The first check should be done after 8 operating hours. Pay attention to the attachment of the cutting blade and the proper bolt torque.
- The attaching flange of the blades or the bolts must not show sign of damage or wear. The bolts must be complete. The blade must be undamaged, evenly worn and adequately sharp.
- If you are driving the machine outside of the working area, always turn off the mowing blades and set the maximum mowing height, otherwise the blades may get damaged.
- Keep the product clean after use. Do not use gasoline or similar oil products for cleaning.
- Do not reach into the space under the mower with your hands or feet. Do not reach under the engine cover or into the gear mechanism.
- If you are forced to reach under the machine, wait until all rotating parts stop. Attention, it takes some time before blade runs down! The run-down time depends on the state and wear of the brake/clutch. Have the brake checked at regular intervals at an authorized servicing facility.
- While operating, wear closed shoes and work clothing. Do not wear loose clothes that could get caught by the machine, short trousers or light shoes.
- It is strictly prohibited for the operator to wear loose clothing.
- A local risk assessment should determine the need for a face shield.
- Do not operate the machine after drinking alcohol or using medication influencing perception.
- Before starting the engine, make sure that the mower blade is disengaged. If the blade switch is in the ON position, the machine cannot be started. When engaging the mower blade, step aside far enough to be protected against object accidentally thrown from the mower and to be able to stop the mower in case of an emergency. Do not enter the path of the mower.
- While operating the mower make sure that the mower is clearly visible at all times and within the range of the remote-control unit and that you can clearly recognize dangerous situations and react to them properly. Do not abuse the maximum reach of the remote control.
- When using the mower, follow all general work safety regulations.
- Work with the mower may only be started if the mower is not damaged by previous operation.
- Do not change the engine tuning, especially the engine speed regulator. Do not modify the exhaust pipe.
- Do not use the mower if there is less than 20% of fuel in the fuel tank.
- Do not move the mower by means of towing it behind another machine.
- The machine should only be used by persons over 18 years of age, who have been acquainted with the machine and the user's manual. The remote control (further referred to as "RC") is considered as a part of the machine
- The user's manual must be stored in a place permanently accessible to the operator and must be available to him at all times.
- Do not allow children or unauthorized persons use the product.
- Before starting to operate the machine, you have to be familiar with all the symbols next to the controls and indicators used on the mower and the RC.
- Pay special attention to the stopping and shutting-off of the engine and to the emergency shutting-off of the mower.
- Before using the mower on a slope, make sure you test and practice your mower-control skills on flat and level ground, which is sufficiently free and spacious. Master how to control the movement on a surface, to mow around bushes, trees and other terrain elements and obstacles.
- When operating the mower on slope, make sure that the engine revolutions are set to maximum speed. If you stop the mower on a slope, position the wheels across the slope.
- While operating or transporting the mower, the operator must always have the mower in their view. The maximum distance between the operator and the mower is 50 m/165 ft.
- While using the mower follow all safety regulations given in this manual and respect local regulations and provisions concerning noise-emissions, especially when using in hospitals, spas and other sensitive areas.
- The operator must pay attention to the area into which the mulched grass may be thrown. Neither the operator, nor any other persons, children nor animals should be allowed to enter this area. If mowing uneven terrain, the ejection and throwing of undesirable objects becomes more probable due to the displacement of the mowing device (tilt of one side of the machine) while crossing the edges of different terrain.
- The operator of the machine may be responsible for any damage caused to third parties by operating the machine.
- The mower may be used on dry surface on slopes listed in chapter 4.3. On wet or moist surfaces, the mowed slope should not exceed 20 degrees when using the machine without use of the integrated stabilizing winch.
- Before operating the machine, make sure you remove all loose stones, sticks, glass, wire, bones, branches and all other objects that can be picked up by the blades and thrown or that could damage the mower from the mowing area.

- While operating the mower avoid obstacles, do not drive over higher obstacles (such as stones, stumps, brick), near precipices, on unstable soil or in places where the mower could fall down or flip over.
- When operating pay attention to electric power lines especially when driving beneath electric wires where the radio signal may be lost. In such case the mower immediately shuts off the internal combustion engine and stops all movements.
- When using the machine near busy thoroughfares make sure that the mower does not endanger (by throwing undesirable objects) passers-by or their property. Choose a suitable working procedure (see chapter: Operating the mower).
- The operator/user is responsible for the safety of persons that enter the working area of the machine. Stop your work if these persons enter the working area.
- The transportation of persons, animals or loads on the mower is prohibited.
- Do not place any objects or tools on the product.
- While operating, especially in windy conditions, choose the operator's position carefully so as to keep the operator away from the stream of exhaust gas, dust or mulched grass.
- Stop work and clean the machine and its cooling surfaces several times while working in dusty conditions to avoid over-heating during operation. If necessary, clean the machine and its cooling surfaces several times while working. The dust layer must not exceed 1 mm.
- Refuel only when the machine is off – before operating, if possible – and the fuel tank is cold. Always keep at least 30% of the fuel in the tank. If you need to refuel during your work, do not fill the fuel into a hot tank or while the engine is still hot. Let the machine cool down.
- Before refueling push the STOP button on the control panel of the mower.
- Never refuel while the engine is running.
- Do not start the engine if you find spilled fuel, open vessels with fuel or other combustible objects or gases in the immediate proximity of the mower.
- Do not refuel near open fire.
- Do not place this product near open fire or other sources of heat.
- While operating or immediately after shutting the machine off do not touch those parts of the machine that heat up during operation. This concerns mainly the engine exhaust pipe, metal parts of the hydraulic drive and metal parts of the internal combustion engine.
- While operating do not touch the high voltage conductor leading to the sparking plug.
- After starting the engine, test the correct functioning of the emergency engine stop on the radio transmitter. This function should be checked at least once during every shift and every time you enter a new area for mowing or mulching.
- Before starting your work test the correct functioning of the safety components (EMERGENCY STOP...) on the mower and the RC.
- Never leave the engine running without supervision.
- If the engine is running, do not put aside the transmitter and do not touch or move any parts of the machine.
- Always stop the engine when leaving the machine, secure it against starting by pushing the red EMERGENCY STOP button on the control panel of mower and by removing the key. Never leave the transmitter next to the mower, but put it in a different, properly secured place inaccessible to third persons.
- Do not engage the mowing blade until immediately before mowing.
- Turn off the mowing mechanism, shut off the engine and remove the key from the ignition every time:
  - You remove dirt from the mowing mechanism (grass or debris).
  - You run over an unknown object and need to check for possible damage or to repair it
  - The machine unusually intensively vibrates and you need to find the cause
  - You repair the engine or other parts of the mower (also unplug cables from sparking plugs)
- While operating, avoid mole-hills, concrete bases, guard-stones, stumps, loose stones and curbs. These must not come into direct contact with the blade as they could cause serious damage. These may also compromise the mower stability.
- Do not drive the mower into heaps of sand, gravel or similar materials
- The mower may only be operated during daylight or under very good artificial light conditions.
- Do not use the mower in limited visibility (dusk, fog, heavy rain etc.)
- Do not let the engine run in enclosed spaces. The exhaust gases contain CO<sub>2</sub>. They damage health and can ultimately cause death.
- The engine should only be started and operating in open spaces. If the engine is started and operated in enclosed spaces, the exhaust gases must be conducted away by the means of prolonging the exhaust pipe outside the enclosed space. Proper ventilation and fresh air supply must be secured in order to prevent the accumulation of CO<sub>2</sub>.
- Before storing the machine in a closed space, let the engine and the hydraulic drive of the machine cool properly.
- Regularly remove all combustible objects (dry grass, leaves...) from the areas around the exhaust pipe, engine, and battery.
- Always control the machine from a working station, which gives you a perfect view of the whole working area and of the machine.
- While working, change your working position to have a perfect view of the mower at all times.
- When operating the mower on slopes never enter the space directly below or above the mower.

- The working position should be far enough (maximum 50 m / 165 ft.) to prevent the operator from getting hit by objects that may be accidentally thrown by the mower.
- Do not operate the mower if you cannot see it (behind terrain obstacles, corners of buildings, hidden in grass etc.)
- Before starting the mower, check the state of the safety labels. If any labels are damaged or missing, contact your dealer and replace such labels on the machine. Get thoroughly acquainted with these labels. The placement of the labels on the machine is obligatory.
- Do not remove or damage any of the safety labels.
- Do not remove any covers or safety elements. They are for your protection.
- Do not use the machine if any of the protecting devices or covers is damaged or missing.
- Keep the machine and its accessories clean and in a good technical condition at all times.
- It is strictly prohibited to make any changes or modifications to the machine that were not previously approved by the manufacturer. Any modification to the machine may lead to a hazardous situation or injury. If these instructions are not followed, the manufacturer does not bear any liability for the machine and the terms of warranty may be invalidated.
- The machine must always be equipped with all covers and protective elements.

### 3.3 SAFETY LABELS

Safety labels are strategically placed around the perimeter of the product to remind you of potential risks.

If you need reading glasses, you must wear them when reading safety labels. Do not overestimate your strength when reading safety labels. If you do not understand the danger shown on the safety label, refer back to: [Safety Label Identification](#).



Keep all safety labels clean and readable. Replace any damaged or lost safety labels. Make sure that the spare parts also contain safety labels if necessary.



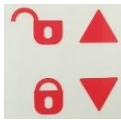

#### **WARNING**

Safety labels on the mower warn against a specific hazard. Failure to follow safety instructions may result in injury.

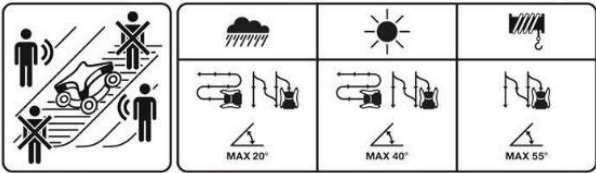
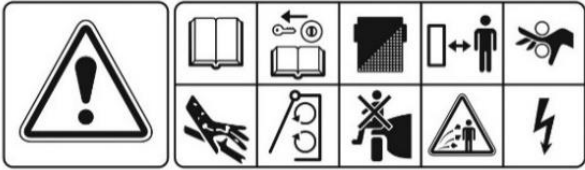
### SAFETY LABEL IDENTIFICATION

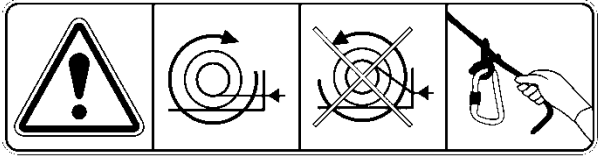
Item	Part No.	Description	Quantity	Label
1	SXP-010	Height of cut label	1	
2	SXP-012	Fuel label	1	
3a	SXP-006	Safe operating distance	4	
3b		Danger of being hit by flying objects		
3c		No manipulation with moving parts until the whole system is stopped		
3d		Warning, do not use your hands as protection when changing the cutting blade		
3e		Attention, danger of being injured by rotating blade		
3f		Attention, do not open or detach the covers while the mower is in use		
3g		Attention, flammable substance, danger of fire		
4a	SXP-005	Danger zone	1	
4b		Climbing ability		
5a	SXP-004	Read the manual prior to usage	1	
5b		When performing maintenance, repair or any intervention on the machine, follow the instructions for use, remove the ignition key		
5c		Wear protective equipment; eye protection		
5d		Keep a safe distance		
5e		Risk of dragging fingers and hand palm into the machine		
5f		Risk of injury from high pressure fluid		
5g		Close all guards before starting up		
5h		Transport of persons on the machine is prohibited		
5i		Hazard warning of flying objects		
5j		Caution electric accumulator		

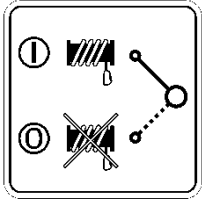
6a	SXP-001*	Correct winding direction of the rope	1	
6b		Wrong direction for rope winding		
6c		When winding / unwinding, keep the rope tightened		
7a	SXP-002	Read the manual before handling	1	
7b		Risk of dragging fingers and hand palm into the machine		
7c		Warning: Do not open, do not remove cover when machine is running		
7d		Switching the machine on / off		
8	SXP-003*	Turning the winch on / off by turning the lever	1	

\* Not included in LITE version

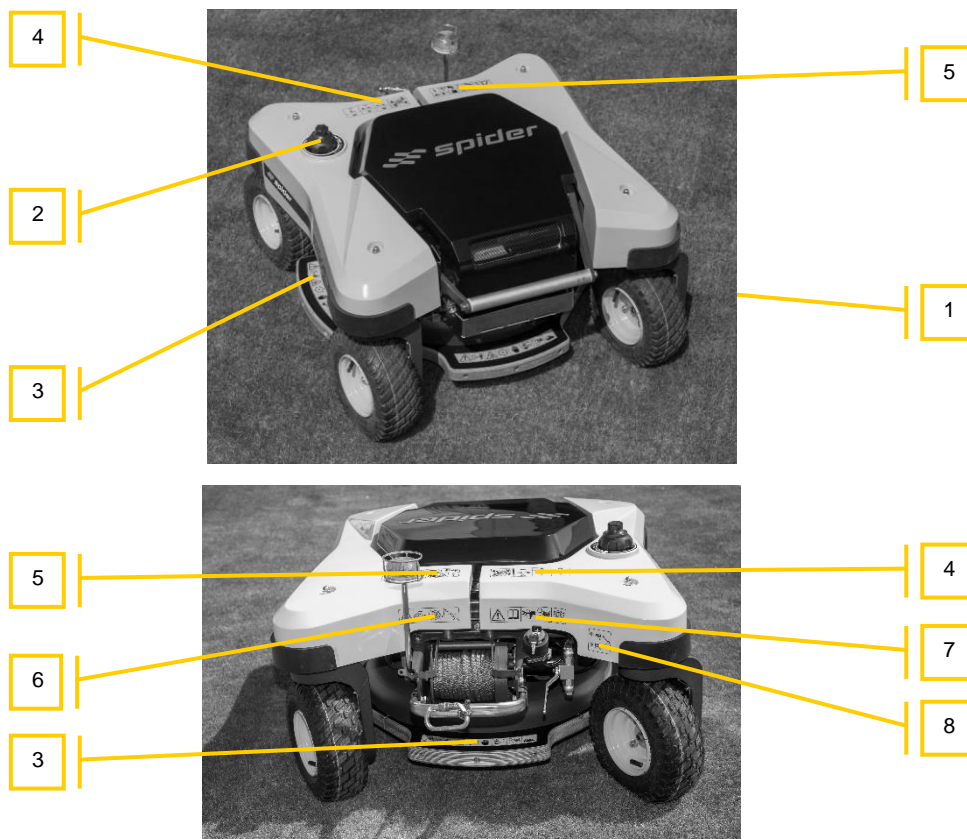

# 4 ABOUT THE PRODUCT

## 4.1 MAIN COMPONENT LOCATION



\*Not included in the LITE version

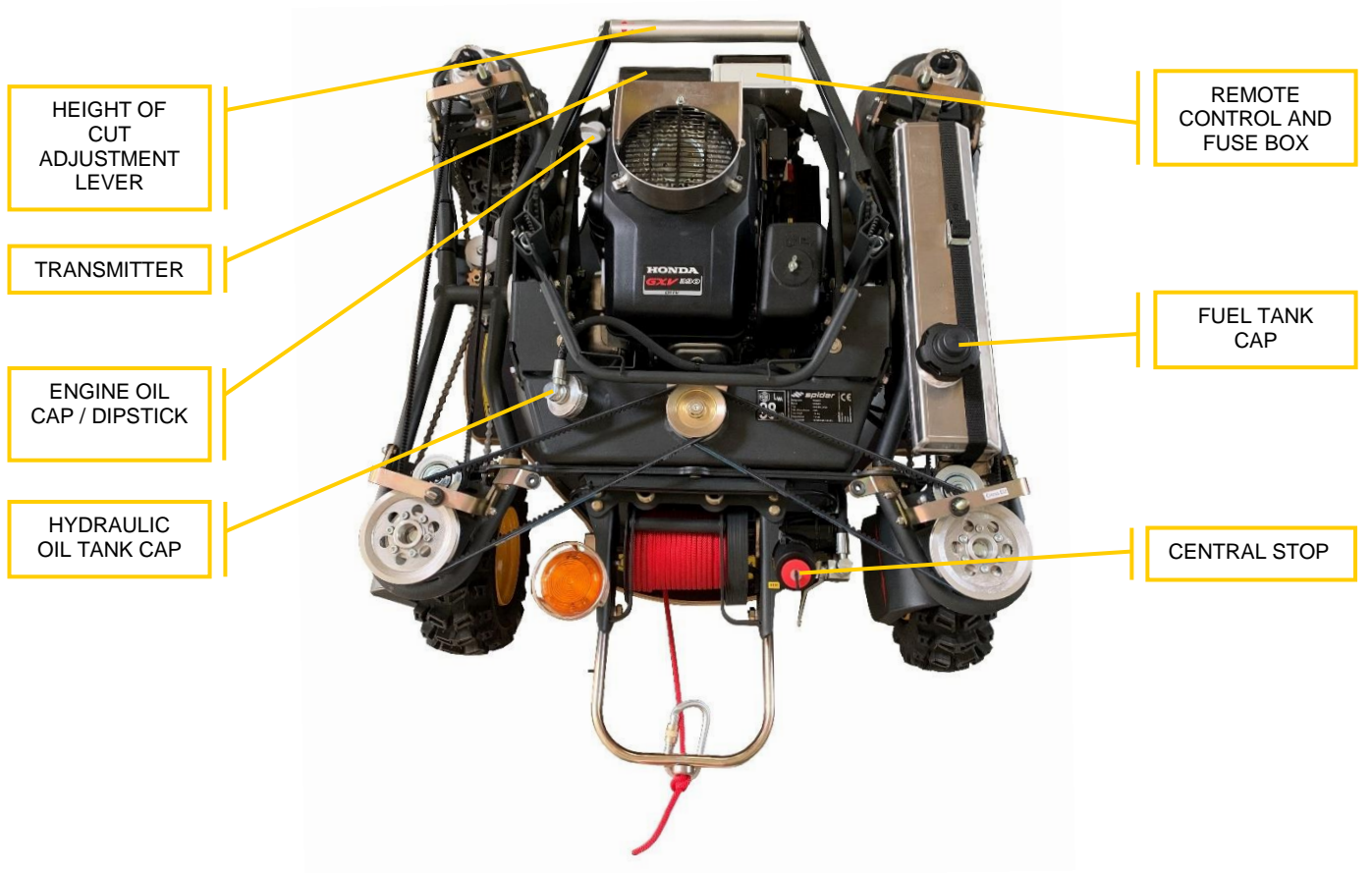

## 4.2 USE OF THE MOWER

The mower is designed to be used for **mowing grasslands on flat and sloping terrain under normal conditions**. The mower's work normally involves mowing or mulching while driving forward, backward and turning. The mower is **operated by one person via a remote radio controller**.

Applications may include mowing and mulching grass on well-maintained but also unmaintained or only occasionally mowed areas. **The mower is not intended for mowing trees, bushes or similar.**

Only authorized, responsible, physically and mentally qualified persons over the age of 18 who have mastered the procedures for proper and safe use and maintenance of the lawnmower and are familiar with applicable regulations and safety and health regulations described in this manual, may use and repair the mower.

Before using the mower while driving it, it is necessary to assess its suitability for the intended use (mower size, performance, technical parameters, etc.). It is necessary to consider the potential hazard properly and to monitor it continuously during operation.

## 4.3 MAXIMUM SLOPE INCLINE

### DRY WEATHER CONDITIONS:

Cutting across a slope:	Maximum slope is 40°
Cutting up and down a slope:	Maximum slope is 40°
Using hydraulic winch	Maximum slope is 55°

### WET CONDITIONS:

All areas	Maximum slope is 20°
Using hydraulic winch	Maximum slope is 55°

### **SPIDER CROSS LINER lite version:**

### DRY WEATHER CONDITIONS:

Cutting across a slope:	Maximum slope is 35°
Cutting up and down a slope:	Maximum slope is 35°

### WET CONDITIONS:

For all areas:	Maximum slope is 20 °
----------------	-----------------------

## 4.4 PROHIBITED USE

- The mower must not be used for any purpose other than that for which it is intended.
- The mower must not be used on areas with glass particles, stones, iron or other unwanted objects that may be thrown by the rotating blade or which may damage the mower.
- The mower can be used on slopes exceeding 20 ° however, in wet, damp or fog conditions, where the slope availability and stability of the mower is adversely affected by adhesion to the substrate, regardless of the type of mowed area you must make use of the stabilizing winch.
- The mower must not be used if people, children or animals are within 15 meters of the machine / mowed area.
- Under no circumstances should the mower be used unless you have thoroughly familiarized yourself with the terrain, in particular the appearance of undesirable terrain irregularities, protrusions, stumps, unbearable spots, marshes, holes, etc.
- The mower must not be used on slopes with a higher slope than specified above.
- The mower must not be used as a towing or transport vehicle.
- It is strictly forbidden to drive the mower on public roads.
- It is strictly forbidden to increase the maximum engine speed or power beyond the manufacturer's specified limits, and to make any other modifications to the machine design or engine settings. The manufacturer bears no responsibility for damages and injuries resulting from such interventions and changes.
- It is strictly forbidden to use the machine after using alcohol or perceptive medication or drugs.
- It is strictly forbidden to drive the mower into piles of sand, gravel and similar materials, stumps, stones, building elements or other obstacles that may cause machine instability.
- It is strictly forbidden to use the machine in poor visibility (twilight, fog, heavy rain, etc.).

## 4.5 HAZARDOUS ZONE

A hazardous area is any area around the mower where the person is at risk from a health and safety perspective. **Keep all persons away from the hazardous area while operating the mower.** People in the danger zone could be injured.

Ensure that the machine operates safely before starting any maintenance procedure - i.e. stopping the mower and turning off all control and safety elements.

The machine operator is trained, responsible and is obliged to evaluate how dangerous the hazardous zone is. In the event of any risk of falling, overturning or similar situations due to the condition of the ground, climate, etc., the operator is obliged to secure or mark a dangerous zone (space strips, warning signs or another trained person who watches the designated area). However, the machine operator is always responsible for the safety around the machine.

**The safety distance between the operator and machine is minimum 5 meters.** If the situation requires less distance from the machine, especially when driving or loading on a transport trailer or driving the machine precisely, the operator is obliged to act with utmost caution and observe all safety regulations!

**The safety distance of other persons is minimum 15 meters.** No persons or operators must be in a danger zone!

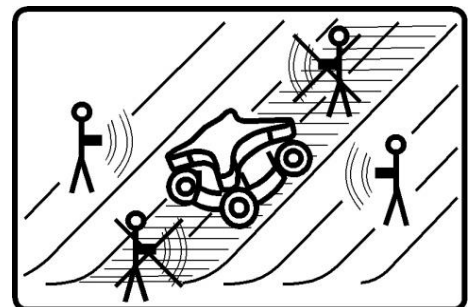

Figure 5 – Hazardous Zones



## 4.6 REMOTE CONTROLLER (RC)

### CENTRAL STOP

Two red colored **CENTRAL STOP** buttons are used to switch the mower off.

One is located on the mower (1), the other on the remote control (RC) (2).



1 – CENTRAL STOP on the mower



2 – CENTRAL STOP on the RC

Both buttons have the same function. **CENTRAL STOP** is a two-position switch. Switching on the mower is done using the key. Pressing the button down turns off all devices.

### STANDARD SHUTDOWN

For standard switching off of the mower press the **CENTRAL STOP** button on the mower and **turn the remote control off** with the **blue main switch on the left side of the remote control**.

### EMERGENCY SHUTDOWN

The **CENTRAL STOP** on the remote control is used for the **emergency stop** of the mower. Always use this type of shutdown when you are unable to approach the mower fast enough or it is generally not safe to approach the mower\*.

### AUTOMATIC SAFETY SHUTDOWN

The mower is equipped with an automatic detection of selected safety parameters. An overview of the parameters can be found in Chapter 3.1 - Safety warnings. If the specified limit value is exceeded, the mower switches off automatically. After the automatic switch-off, **it is always necessary to switch off the mower manually using the CENTRAL STOP** button on the mower and the remote control using the main switch.

### AUDIBLE WARNING

The machine will automatically give a warning if no connection is established or if the connection is lost (turning off the remote control):

The audible alarm sounds:

After switching on the controller and the mower: after **60 seconds**.

After signal loss between controller and mower: after **10 seconds**.

## REMOTE CONTROLLER



A - forward direction  
B - reverse direction

C - steer right  
D - steer left

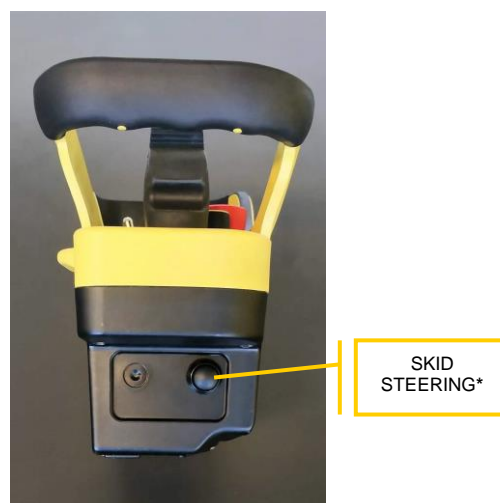
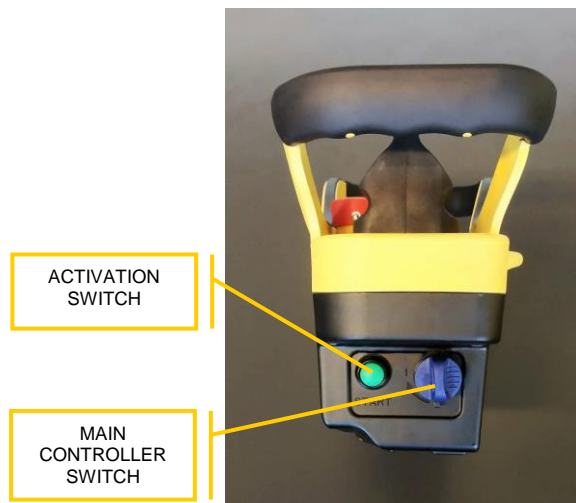

## REMOTE CONTROL BATTERY

The controller's battery is shown in the figure.  
Remove the battery from the controller to recharge it.

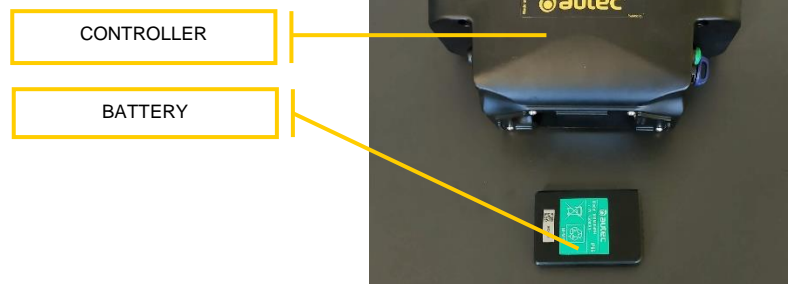

\*Not active in lite version

## LIGHT SIGNALS

The remote radio has two LEDs near the STOP button.



GREEN LED	RED LED	MEANING
OFF	OFF	Controller is OFF
Flashing intensively	OFF	Controller and receiver are not connected.
Repeats sequentially: flashing + pause	OFF	Controller is ON and units are communicating on the frequency 863-870MHz.
Repeats sequentially: 2 flashes + pause	OFF	Controller is ON and units are communicating on the frequency 915-928MHz.

The red signal prevails over the green one when both LEDs are lit at the same time.  
LED Fault signals are described in the enclosed instructions for the control unit.

## 4.7 CONTROL UNIT AND WIRING HARNESS

### CONTROL UNIT – PREMIUM VERSION

The **SPIDER CROSS LINER – PREMIUM VERSION** mower is equipped with a control unit with an LCD display, a control button and a service connector. The display provides information on service intervals, operating hours, radio signal status and possible system errors.

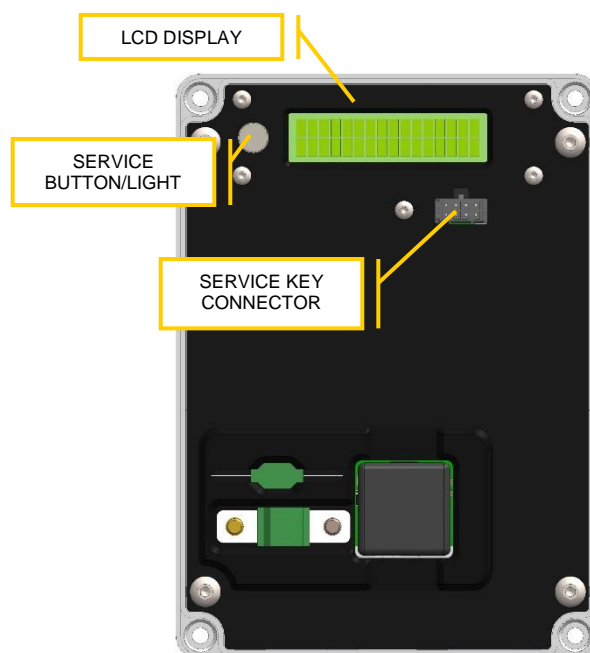

Front panel of the Cross Liner control unit without protective plexiglass

## LITE CONTROL UNIT

The **SPIDER CROSS LINER – LITE** version, is equipped with a control unit with a service key connector for switching to service mode when necessary. It does not include the LCD display or control button.

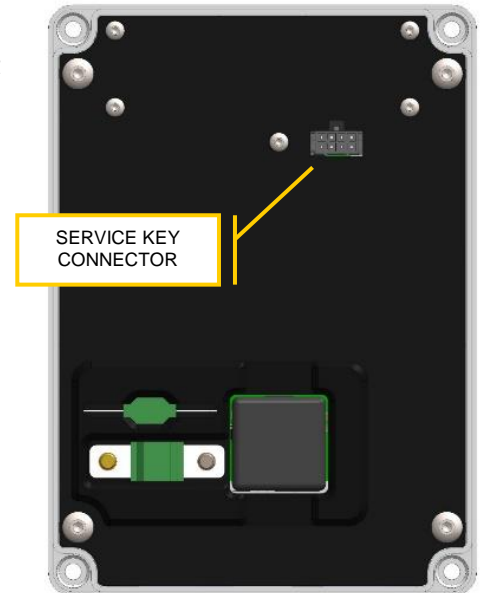

Front panel of the Cross Liner LITE control unit without protective plexiglass

## LAUNCHING THE PREMIUM CONTROL UNIT

After starting the mower, the data is read into the control unit. The control button lights up red during loading and the message:

```
Device status:
Loading...
```

## SERVOMOTOR INSPECTION

After successful data reading, the display shows the pairing status of the individual servomotors. To work with the mower, it is necessary for all servomotors to be paired with the control unit.

Paired servomotors are marked with the "-" symbol.

If all servomotors are successfully paired, the following message will appear on the display:

```
Device status:
LRAC -> ----
```

If one of the servomotors cannot be recognized by the control unit, the "X" symbol will appear next to that servomotor. In this case, it is necessary to rectify the fault first, or contact an authorized service center.

The servomotors are shown in the following order:

1. Left wheel steering servomotor (L)
2. Right wheel steering servomotor (R)
3. Travel servomotor (A)
4. Mowing system servomotor (C)

```
Device status:
LRAC -> --X-
```

Sample message in case of unpaired travel servomotor.



## OPERATION

After successful pairing of the servomotors, the LED control button goes out and the system switches to normal mode.

The display shows basic operating information:

```
Total mower start time  → Pwr: 26 hrs $
Total number of operating hours → Act: 25 hrs !R
                                     ↑
                                     Status icons
```

The following status icons appear on the right side of the display:

Status icon	Meaning
	The service interval is approaching (for service intervals, see chapter 8.2)
	The radio connection to the controller was not established or was lost.
	GPS signal detected successfully.

If the system detects an error, an error code is displayed on the second line. See chapter 8.11 for more information on error codes. - Electrical system

## 5 OPERATION

The purpose of this part of the manual is to guide the operator to become familiar with the use of the mower step by step so that they can work with it efficiently and safely.



The user / operator is the person responsible for the safety of persons who enter and are in the working area of the mower. The mower operator is responsible for any damage caused to third parties by the mower's operation.

The mower may be used to work on slopes with a slope specified in chapter 4.3 MAXIMUM SLOPE INCLINE.

Before operating the mower for the first time, each owner is obliged to ensure the general training and practical skills training of his / her staff - the operators how to control the mower. General training and practical skills training will be carried out by the sales representative/product specialist from the mower supplier.

### 5.1 MOWER SAFETY INSPECTION

Before you start working with the mower, it is necessary to perform the following check. If defects appear during the inspection, they must first be rectified before the mower can be started.

#### MOWER CLEANLINESS

- Remove dirt and debris, especially near the joints, pins engine and exhaust, covers, alternator, starter and controls.
- Clean all safety labels with instructions. Replace any missing or unreadable labels.
- Perform a thorough inspection to identify any defects or deficiencies.

#### OPERATING FLUIDS

- Check the engine and hydraulic oil levels
- Check the fuel level (if less than 20% of fuel in the tank, refuel immediately)
- Check for leaks underneath the mower
- Ensure that all filler caps are properly installed and closed.

#### TIRES

- Check the tire pressures and their overall conditions.

## MOWING SYSTEM

- Check the condition of the blade (The blade must be sharpened and free of any deformations).
- Check the blade screw for tightness.

## SAFETY ELEMENTS

- Check the function of both CENTRAL STOP buttons, remote control and signal transmission.
- Visually inspect the bolts and nuts for tightness.
- Check that all safety labels are readable on the machine.

## STABILIZING WINCH (not incl. in LITE version)

- Check the condition of the winch rope and placement on the drum.
- Check the condition of the carabiner.

## 5.2 STARTING THE ENGINE

Before starting the engine, a check-up of the mower must always be performed (see chapter 5.1).



Make sure the joystick is in the neutral position and the blade switch is off.

- 1) Turn the controller on with the controller main switch into position 1.

MAIN SWITCH



- 2) Activate the CENTRAL STOP on controller (by turning the CENTRAL STOP clockwise).

CENTRAL STOP



- 3) Unlock the CENTRAL STOP on the mower to the ON (clockwise) position.

CENTRAL STOP

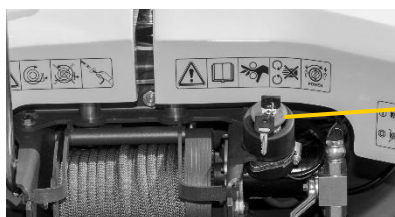

- 4) Press the activation switch on the left side of the controller.

ACTIVATION SWITCH



MAXIMUM ENGINE SPEED



- 5) Set the engine RPM control to maximum
- 6) Hold the switch to the start position and hold it in this position until the engine starts.

ENGINE START/STOP SWITCH



- 7) After starting the engine let the machine stand for 2 minutes until the engine is sufficiently warmed-up.



To work with the machine, keep the engine speed set to maximum.



If the engine fails to start, the mower functions will be blocked again. In this case, it is necessary to move the engine start lever to the off position and repeat the entire starting procedure from the first point.



If the engine repeatedly fails to start, see Chapter 9 Faults and Remedies for an overview of possible causes and recommended measures.



**WARNING**

If any of the hazard warning lights stop while the engine is running, or if it does not turn off properly, stop the engine as soon as it is safe to do so.

### 5.3 STOPPING AND PARKING



**WARNING**

An incorrectly parked mower may spontaneously move in the absence of the operator. Follow the instructions in the operating instructions for proper parking methods.

**Stop the mower on dry and level ground**, where the mower will not pose a risk and / or danger. If you must stop the mower on a slope and take any action, interrupt work or switch off the engine, etc., **turn the wheels perpendicularly to the slope**. This will prevent the mower from moving down the slope.

- 1) Reduce the pressure on the travel joystick gradually so that the mower stops smoothly - the joystick will be in the neutral position.

DRIVE JOYSTICK IN THE NEUTRAL POSITION

- 2) Reduce engine speed.

MINIMUM ENGINE SPEED



- 3) Switch the cutting deck switch to "OFF BLADE".



MOWING DECK OFF

- 4) Hold the switch to the engine OFF position.



ENGINE STOP

- 5) Press the CENTRAL STOP on the mower.



CENTRAL STOP

- 6) Switch off the remote controller by turning the main switch.



MAIN SWITCH

## EMERGENCY STOP

For an emergency shutdown use the CENTRAL STOP button on the controller. Use the CENTRAL STOP on the mower only when the mower is stable and on a level ground or you are in the immediate vicinity of the mower making sure it does not pose any risk to you or others.



### WARNING

The CENTRAL STOP buttons on the controller and on the mower should be used whenever an emergency stop is required.



**WARNING** If the wheels of one side of the machine are deflected when the machine is switched off (eg by handling during transport), the wheels are automatically aligned to the position before the wheels are deflected when the mower is switched on by unlocking the CENTRAL STOP button. Danger of injury!

## 5.4 DRIVING THE MACHINE

When driving, make sure that you keep the mower under control at all times. It is necessary to pay attention to various obstacles and always keep in mind possible dangerous situations.

Drive the mower slowly to be able to react to the direction in which the mower is moving. When descending a slope, the appropriate speed must be selected in advance. You need to choose the speed with regard to the risks.



### WARNING

Beware when moving the forward / reverse drive joystick while driving as it can cause injury to you and others. The mower can change direction suddenly and without warning. The lever must be handled exactly as instructed.



**WARNING**

It is forbidden to drive the mower (without doing any work) with the mowing mechanism switched on.

**SPEED SELECTION**

Always choose a suitable driving speed that will allow for a satisfactory mowing quality. When selecting a speed, always go from lower to higher speeds, not vice versa. The travel lever is used to regulate the speed

The speed range can be changed with the turtle/rabbit lever. Switch to rabbit mode for a higher speed range.

**WARNING**

**Never reduce the speed by reducing the engine speed!** The speed should only be adjusted by use of the drive joystick or the turtle / rabbit switch.

**SPIDER MODE**

The mower is equipped with a unique SPIDER mode control system (also known as the “dance step”), thanks to which all 4 wheels turn a full 360° unlimited, so there is no need to rotate the machine if you need to change direction.

**SKID-STEERING**

Skid-steering is used to rotate the machine around its vertical center axis. You will appreciate it especially when cutting around various obstacles and when approaching a transport trailer or other transport vehicle.

**To skid the mower:**

- 1) Stop the mower on a flat surface and turn the wheels straight in the direction of the winch.
- 2) Hold the skid steer button so that the wheels turn until one side is turned 180° in comparison to the other side.
- 3) After the wheels have turned into the correct position, while still holding the skid steer button, push the joystick forwards to turn clockwise or backwards for counter clockwise.

**WARNING**

Always skid-steer on a level, firm and horizontal surface. Skid-steering can cause unwanted terrain erosion.

**WARNING**

Skid-steering serves only for minor corrections to the mower's direction. The angle gears and tyre treads suffer when skid-steering too often.

**5.5 CUTTING BLADE ON/OFF**

To switch the cutting deck on, use the blade on/off switch.

To turn the cutting deck off, switch the blade on/off switch to OFF.



MOWING BLADE ON / OFF SWITCH

**WARNING**

Keep the blade switched on when you are mowing. Always switch off the blade when moving between mowed areas.

## 5.6 MOWING HEIGHT ADJUSTMENT

The mowing height can be adjusted in 4 position between 45 - 110 mm. The cutting height is adjusted using the lift handle on the mower. Only adjust the cutting height when the mowing deck is switched off.

### To set the cutting height:

- 1) Stop the mower on a level surface and turn the mowing deck off.
- 2) Turn the handle according to the pictogram and set the desired cutting height.
- 3) Release the handle and secure the desired height.

### WARNING



The mowing deck is supported by strong springs that reduce the force required to change the mowing height. The cutting height should only be changed when the mower is firmly standing on all wheels. When the cutting height lever is unlocked, the lever may be ejected upwards when not held in place.



For tall or wet grass, select a higher mowing position. The lowest position should only be used when mowing flat and well-maintained areas.

## 5.7 DRIVING ON SLOPES

Driving on slopes requires the operator to constantly evaluate information regarding the mower's movement on the slope and the terrain conditions. It is especially important to evaluate the grip of the wheels on the grass or other surfaces and the angle of inclination of the mower. Pay attention to climatic conditions.

**The performance of the mower will vary considerably on a dry, damp or wet slope surface!**

### ESSENTIAL RULES FOR DRIVING ON A SLOPE

- When working on a slope, start from the bottom and work your way to the top. Only select a top-to-bottom mowing procedure in exceptional circumstances and only on well-known terrain.
- Always start on a lower slope angle. This will allow you to better evaluate slope conditions and choose the correct work approach. If you work on a slope with a steeper angle, the mower may slide due to unfavorable adhesion conditions. Due to the dynamic effects, the mower can also overturn.
- If the mower starts slipping, do not attempt to stop or access the mower, especially not below or directly above it.
- Do not touch or approach the mower if the wheels have been raised off the ground or the mower is tilted excessively or is in an unstable position or is already overturning.

### AVOID

- Sudden changes with steering or braking
- Steep inclines, braking on a slope or sudden change of direction
- High speed driving
- Uneven substrate or ground
- Variable adhesion (shifting from sunny to shady places, etc.)
- Travel along the cut material
- Stop on the slope and stop the engine



### WARNING

If the slope surface is wet or damp, the maximum slope inclination permitted to work on is 20°.

## 5.8 HYDRAULIC STABILIZING WINCH\*

The mower is equipped with an integrated stabilizing hydraulic winch (hereinafter referred to as "winch"), which is designed as a stabilizing device and improves the mower's stability on a slope. It prevents the mower from sliding downhill and reduces soil erosion.

There shouldn't be any obstacles that could jam or damage the rope – such as trees, bushes, etc. – in the operating area between the anchoring point and the mower.

### IT IS FORBIDDEN TO USE THE WINCH

- If any parts of this equipment are **damaged or show considerable wear**, e.g.: rope, carabiner, etc.
- **For purposes other than stabilizing** the SPIDER CROSS LINER.
- **For removing objects**, securing people or objects on a slope.
- On slopes **where there are terrain obstacles** and there is a possibility of damaging the rope or getting caught on a slope.
- In places where the **anchoring point is not strong** enough and can be loosened after anchoring and working with the mower.

### SAFETY INSTRUCTIONS

- Always keep the winch and its accessories clean and in good condition. After finishing work, clean it by sweeping and wiping. Do not use gasoline or similar petroleum products for cleaning.
- Do not anchor the winch rope over roads, sidewalks or other public areas.
- When working with the winch, select the working position so that you do not move under or directly above the machine and do not cross the rope path. There is a risk of injury when the machine slips or the operator may slip and fall under the mower.
- Use the winch only for stabilization with the engine speed set to maximum.
- Do not reach into the winding drum with any part of your body in order to straighten the rope. The rope is wound up along its current position on the winding drum.
- The carabiner must not strike or be subjected to additional external forces (pull only).
- Follow the procedure for attaching the winch rope to an anchoring point.
- The carabiner must always be properly closed (locked) with the locking segment - the carabiner can only work safely with the lock properly tightened.
- Check the mowing area carefully. Orient yourself, assess the situation and test the possibilities of the terrain. Do not take chances. It is necessary to inspect the terrain thoroughly before starting work.
- Work on a slope from the bottom towards the top. You will work, generally, from a lower to a higher incline, which will give you a better chance to evaluate the climbing ability and make the right decisions concerning further work. Be aware of the dynamic effects of the mower while mowing, which can cause considerable strain on the winch rope and anchoring points.
- If the mower slips, do not try to stop it and do not approach the mower, especially in the area under or above the mower.
- Always stand aside while operating, never directly above or below the mower.
- Before working on a slope, ensure that no one is moving beneath the mower or in the general mowing area. Do not endanger third parties or property with the machine.
- Choose your operating position outside the area where the mower can slide / fall or the mowed grass is ejected. The direction of the ejected grass may change with respect to the direction of travel during machine operation.

### WHILE WORKING WITH THE MOWER YOU SHOULD AVOID

- sudden sharp steering or braking
- driving too fast
- unstable soil and driving on uneven surfaces
- changing wheel adhesion (driving from areas exposed to sun to shade etc.)
- driving on the grass that has already been cut

## MAIN COMPONENTS



\*Not included in the LITE version

## WINCH CONTROL

### POWER ON

To switch the winch on, set the valve lever to position 1 to activate the hydraulic oil inlet to the winch hydraulic motor.

### POWER OFF

To turn the winch off, move the valve lever to position 0, further rotation of the winch drum is stopped.

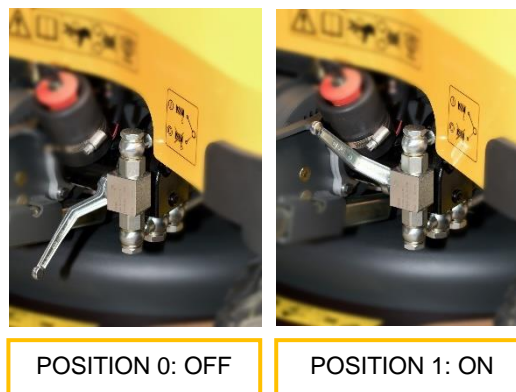

### WARNING

Only approach the mower if the mowing blade is switched off and the engine speed is set to minimum.

## ANCHORING THE ROPE

For best use of the winch and optimum tension force on the rope, it is necessary to choose a fixed point to which you can anchor the end of the rope with the carabiner.

### WHEN SELECTING THE ANCHORING POINT MAKE SURE THAT:

- There are no objects, trees, bushes, etc. in the area of the mower and rope movement that could be affected or damaged by the rope or damage the rope.
- The surface of the anchoring point is smooth without sharp edges and the rope with the carabiner stays in a set position for the whole duration of the operation.
- Attach the end of the rope (carabiner) to an anchoring element at a height of approx. 30 cm if possible (Never anchor the rope directly to the ground).
- The anchoring point is sufficiently strong to withstand a minimum load-bearing capacity of 200kg.

## WINCH ANCHORING PROCEDURE

- 1) Drive the mower to the chosen area and place it on level ground under the slope you intend to mow, directly below the anchoring point
- 2) Turn the mower wheels perpendicular / across to the slope.
- 3) Make sure the mowing blade is switched off and set the engine speed to minimum.
- 4) Set the valve lever to position 1 (ON).
- 5) Slightly deflect the drive joystick on the remote control backwards the winch will start to unwind.  
*(The winch is pre-set to unwind when the driving joystick is deflected in the BACKWARDS direction – towards the operator. In case the rope winds up instead of unwinding, completely unwind the winch rope (in this case by deflecting the joystick forwards), when completely unwound keep deflecting the joystick forwards and start winding in the winch rope.)*



When the mower travel control lever is slightly deflected, there is no travel, but only the winch is operated and the tow rope can be unwound or rewound.

- 6) Release the screw lock on the carabiner, mount the rope to the anchoring point, secure it properly by fastening the screw lock.
- 7) Deflect the drive joystick forwards in order to wind in the loose rest of the rope. The rope on the winch drum should be slightly tight.
- 8) Increase the engine speed from minimum to maximum.
- 9) Turn the wheels of the mower up the slope (FORWARDS) and slightly deflect the driving joystick on the remote controller forwards.
- 10) If the rotation of the wheels of the mower and the direction of the rope winding corresponds (i.e., the rope is winding up when the mower is driving up the slope) you can start mowing. If the rope unwinds when travelling up the slope, stop the mower and turn the wheels 180°
- 11) Make sure and constantly check that the rope is properly winded on the winch drum and that it is not lose or tangled. In that case it is prohibited to use the mower on slopes.



**The operator is responsible for selecting a suitable anchor point**

## MOWING WITH USE OF THE WINCH

Driving on slopes requires the operator to constantly evaluate information regarding the mower's movement on the slope and the terrain conditions. It is especially important to evaluate the grip of the wheels on the grass or other surfaces and the angle of inclination of the mower.

Pay attention to climatic conditions. Do not rely blindly on securing the mower with the winch. The climbing ability of the mower will be radically different on dry, wet or moist grass slopes.

The climbing ability and the mower's behavior will also depend on the surface conditions. On a newly built slope, the probability of slipping will be significantly higher than on solid ground.

## DRIVING METHOD WITH USE OF THE WINCH



### WARNING

Driving on a slope places a number of demands on the operator, and during the movement on the slope, the operator must constantly evaluate information about the movement of the machine and the characteristics of the terrain.

Pay attention to climatic conditions. Do not rely on the rope to secure the mower. The slope accessibility of the mower will vary significantly on dry, damp or wet grass. It will also depend on the looseness of the grass cover. On a freshly built slope, the side descent will be significantly higher than on a hard surface.

## METHOD FOR MOVING DOWN A SLOPE

When using a winch, move only along the slope, not along the contour. Make sure that the rope is always tight. Do not drive into bushes or similar obstacles (even when driving downhill), as the mower may stop because of these obstacles and the rope may come loose and get tangled.



### WARNING

The mower must always travel in accordance with the WINDING direction in order to maintain the stabilizing function. Failure to do so may result in the rope becoming loose and tangled in the drum

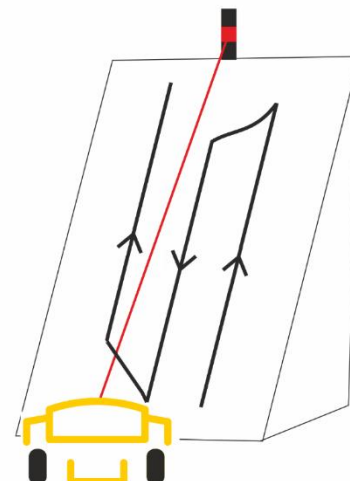

## 6 STORAGE

### 6.1 CLEANING

- Before cleaning the machine, turn the engine off and wait for it to cool down.
- Cleaning the machine with high water pressure is not recommended. Pressurized water can enter the electrical parts, carburetor or air filter and cause the mower to fail.
- Avoid using water around electrical components, as this could cause irreparable damage to the control unit.
- We recommend cleaning the engine compartment with compressed air or a damp cloth.
- Grass deposits should first be removed with a scraper and then washed with soapy water.



#### **WARNING**

Always follow local regulations regarding the handling of waste generated when cleaning the mower.

### 6.2 STORAGE

If you are not going to use the mower for a long time, you must store it properly. If you prepare the mower carefully and take care of it continuously, you can prevent deterioration and damage to the mower during storage.

#### **PREPARING THE MOWER FOR STORAGE**

- 1) Clean the mower and remove any unwanted material or corrosive products.
- 2) Apply grease to the moving parts.
- 3) Check that there are no worn or damaged parts on the mower. Replace if necessary. Pay attention to belt distributions
- 4) Check the levels of all fluids. Top off if necessary (except fuel).

#### **LONG TERM STORAGE**

- 1) Park the mower on a firm, level surface and is easily accessible. If storing on an inclined floor, secure the machine from rolling.
- 2) Make sure all caps are closed.
- 3) Remove the key from the CENTRAL STOP button.
- 4) Remove the battery from both the mower and the RC.
  - Keep the batteries dry and warm.
  - Charge the batteries periodically.
- 5) If you are keeping the mower in the open area, cover it with a tarpaulin.

#### **PRE-SEASON PREPARATION**

- 1) Check all fluid levels. If necessary, top off to the recommended level.
- 2) Install fully charged batteries on mower and remote control.
- 3) Start the engine
- 4) Test all operation functions.

## 6.3 REFUELING THE MACHINE

### SAFETY PRINCIPLES

- Choose a well-ventilated area for refueling.
- Do not refuel while the engine is running or when parts of the mower have a high temperature. Always wait until the mower temperature cools down.
- Protect the fuel system from open flames, do not smoke when refueling.
- If a fuel spill is suspected, stop the engine immediately. Spilled fuel can cause a fire. Clean the spilled fuel immediately.



#### ATTENTION

In the event of an engine failure caused by the quality and type of fuel used, the manufacturer does not accept any liability.



Always refill the fuel tank at the end of the work shift. This will prevent condensation in the tank.

### FILLING THE FUEL TANK

- 1) Secure and turn off the engine by use of the engine start/stop switch.
- 2) Remove any unwanted material from around the fuel cap.
- 3) Remove the fuel cap.
- 4) Add fuel through the filler neck as required.
- 5) Install the fuel cap. Make sure it is properly tightened.

ENGINE START/STOP SWITCH



## 7 MOWER TRANSPORTATION



#### WARNING

Driving the mower on public roads is prohibited.

The mower can be transported using a trailer or on the loading area of a transport vehicle.

Make sure that the loading ramps have enough load capacity. The load capacity must correspond with the weight of the mower listed on the production plate.

Before loading the mower onto the transport vehicle, make sure that:

- The loading ramps are long enough and are free of any grease or ice
- The mower is properly aligned with the loading ramps to avoid the risk of falling.

The mower must be properly secured for safe transport. Use the points marked with the chain symbol to secure the mower.

For fastening, thread the securing strap around the engine girder and hook the strap to the anchoring loop. Fasten both sides of the mower.

ENGINE GIRDER



#### ATTENTION

Take extra care around the exhaust pipe before passing the securing strap. If the engine is still warm, it may cause burns to limbs or strap! We therefore recommend using protective gloves.



## 8 MAINTENANCE

The SPIDER CROSS LINER mower has been designed to be safe to work in demanding conditions while being productive and economical.

Regular attention must be paid to regular maintenance. Neglecting maintenance can damage the machine and can even make the mower dangerous for both the operator and his surroundings. Therefore, strictly follow the maintenance schedule given in chapter 8.2. MAINTENANCE SCHEDULE

### SPARE PARTS

The use of non-genuine spare parts and consumables exposes the mower operator to risks and can also cause the mower to malfunction.

An overview of spare parts can be found in the spare parts catalog, which you will receive together with these operating instructions when handing over the SPIDER. You can then order the parts on the e-shop, which can be found on the website [www.spider-cz.com](http://www.spider-cz.com). It is necessary to register in advance for the order.

### 8.1 MAINTENANCE SAFETY

#### Compressed air

Compressed air is dangerous. Always wear personal protective equipment. Never aim the compressed air nozzle at yourself or others.

#### Springs

Always wear personal protective equipment when removing assemblies containing spring-loaded components. This will protect you from potential eye injuries caused by flying parts.

#### Metal chips

You may be injured by flying metal chips when pulling out or inserting metal pins. Use a soft surface hammer or a copper mandrel for insertion or removal i.e. pulling out metal pins. Always wear personal protective equipment.

#### Hydraulic pressure

Hydraulic fluids under pressure can hurt you. Before connecting or disconnecting any hydraulic hoses, the hoses must be free of any hydraulic pressure. Secure the mower so that it cannot be started when the hoses are loose.

#### O-rings and gaskets

Poorly fitted, damaged or blistered O-rings and gaskets may cause leaks and accidents. In case of damage, replace them if no other instructions have been given. Do not use trichloroethane (TCA) or paint thinners near 'O' rings and seals.

#### Welding

Welding directly on the mower is prohibited

#### Hot parts

Contact with hot surfaces can cause skin burns. The engine and mower components will be hot after operation. Allow the engine and components to cool down before servicing.

#### Lifting the mower

Under no circumstances should the engine run while lifting the mower. If the joystick is inadvertently moved, stability may be at risk

#### Fuel

Fuel is flammable, so protect the fuel system from open flames. If you suspect a fuel leak, stop the engine immediately. Do not smoke when refuelling or working on the fuel system. Do not refuel while the engine is running. Clean any spilled fuel as it may cause a fire. Failure to observe these precautions may result in fire or injury.

#### Exhaust gases and toxic CO (carbon monoxide)

Ensure adequate ventilation in work areas before each engine start

### WASTE DISPOSAL



#### WARNING

It is forbidden to pollute bodies of water, sewers or soil. Remove all spills and / or lubricants.  
**All waste products must be stored in accordance with all local regulations**



#### WARNING

Damaged or burnt batteries, as well as charred debris in the event of fire and fluid leakage, should be placed in a sealed, acid-resistant container and disposed of in accordance with local waste disposal regulations.

**Oil Storage**

Lubricants should always be stored so that children do not have access to them. Never store the lubricant in open or unlabeled containers.

**HANDLING OIL AND LUBRICANTS****ATTENTION**

The hydraulic oil temperature will be high right after the engine stops. Wait until it has cooled down before starting maintenance.

**Used oil**

The following precautions should be taken when handling used engine oil in order to protect your health:

- Avoid prolonged, excessive or repeated skin contact with used oil
- Lubricate your hands with a protective cream before handling these oils.
- Observe the following guidelines when removing oil from the skin:
  - Wash your skin thoroughly with soap and water
  - It is useful to use a nail brush
  - Use special hand cleaners to clean them properly (Avoid using gasoline, diesel or paraffin on the skin)

**FIRST AID – OIL****Eyes**

If you get oil in your eyes, it should be washed with water for about 15 minutes. If irritation persists afterwards, seek medical attention.

**Ingestion**

If you accidentally swallow oil, do not try to induce vomiting. Check with your doctor.

**Oil spill**

Allow spilled oil to soak into sand or absorbent granules that are allowed in the area. The stains should then be scraped off and disposed in an appropriate waste container or landfill.

**Fire**

Do not use water to extinguish an oil fire. This would only spread the fire, as the oil floats on water. Extinguish burning oil and lubricants with carbon dioxide powder or foam extinguishing agents.

**8.2 MAINTENANCE SCHEDULE**

To ensure the long life of your mower, it is essential to perform regular maintenance. The maintenance schedule below informs about the actions and intervals.

**Perform service tasks at intervals of:**

- Hours worked
- Calendar equivalents

Whichever occurs first.

**ATTENTION**

If the mower operates in difficult conditions (high temperature, dust, water, etc.), shorten the intervals.

Maintenance intervals must not be exceeded. If any faults are detected during maintenance, rectify them before working with the mower.

Some service requirements must be done by qualified technicians. Such operations are labeled with the letter “S” in the following maintenance chart.

## MOWER MAINTENANCE CHART

X = Operator S = Authorized service * = in dusty areas to be performed more frequently	Each Use	First Month or 20 Hrs	Every 3 Months or 50 Hrs	Every 6 Months or 100 Hrs	Every Year or 200 Hrs	Every Year
Check for oil leakage from engine and hydraulic systems	x					
Check the level of engine and hydraulic oil	x					
Check the tyre pressure	x					
Check electronic and safety devices (emergency stop, steering, signal etc.)	x					
Check for loose blade bolts	x					
Check for loose screws and nuts (visually)	x					
Check blade sharpness and deformations	x					
Check safety decals on the machine	x					
Check the winch rope	x					
Check the carabiner	x					
Clean the engine cooling system, exhaust hood, alternator, starter, hydraulic pump and controls	x					
Clean air filter and rough filter	x					
Check and clean the mowing mechanism	x					
Check the tension and state of drive belts (visually)		x				x
Check the tension and state of the steering chain (visually)		x				x
Check and adjust wheel geometry		x			x	
Change engine oil		x		x		
Check the winch drum state			x			
Check for loose screws and nuts			x			
Check the mower battery state of charge			x			
Check hydraulic hoses, fuel hoses, cables (visually)			x			
Check the state of the bearings on the mowing device			x			
Replace the air filter and rough filter					x *	
Replace the fuel filter, clean the fuel tank					x*	
Replace the spark plug					x	
Change the hydraulic oil and filter					x	
Check the valve clearance					S	
Check, adjust and refill the wheel portal					S	
Check the blade deceleration					S	
Adjust the neutral position of the machine drive						x



### 8.3 MOWER SERVICE POSITIONS

The Spider Cross Liner offers two different service positions

#### VERTICAL SERVICE POSITION

The vertical service position is used for cleaning and maintenance of the cutting device. The mower must be placed in this position on a firm and level surface only for the duration of the service.

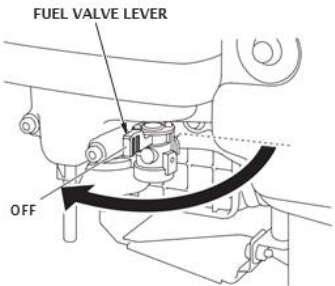
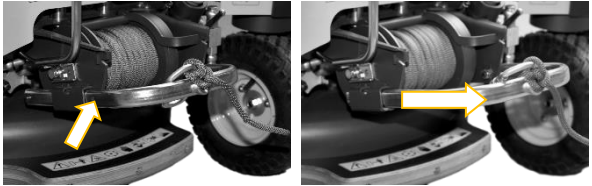
#### PROCEDURE:

1	Place the mower on a level and solid surface.	
2	Rotate the wheels so the wheels are aligned with the cutting height adjustment lever.	
3	Switch off the mower and the remote control.	
4	Check and make sure the fuel and oil tank caps are closed tight.	
5	Turn the fuel valve off.	
6	Set the height of cut to the third position from the top.	
7	Pull the winch guide towards you. It will partially eject. (NOTE: If the winch rope is too tight, the winch guide won't pull out. Loosen winch rope)	
8	Lift the mower on the winch side by the winch guide until the mowing height handle rests on the ground.	

**HORIZONTAL SERVICE POSITION****PROCEDURE:**

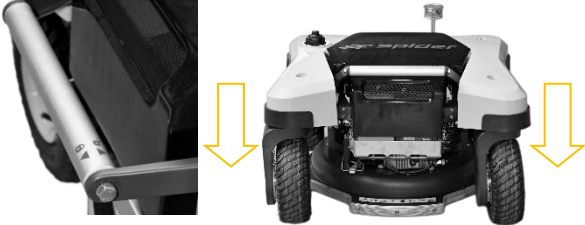
1	Place the mower on a level and solid surface.	
2	Switch off the mower and the remote control.	
3	<p>Unlock and adjust of the cutting height lever to the lowest possible level so that the mowing platform is resting on the floor, then lift the handle bar thereby lifting the wheels of the ground slightly, then secure the lever again. (see pictogram on the handle)</p> <p>Tip: for easier working on the machine, support the mowing deck (e.g. with wooden beams)</p>	
4	Check the stability of the machine.	

## 8.4 SERVICE POINTS

### ENGINE AREA

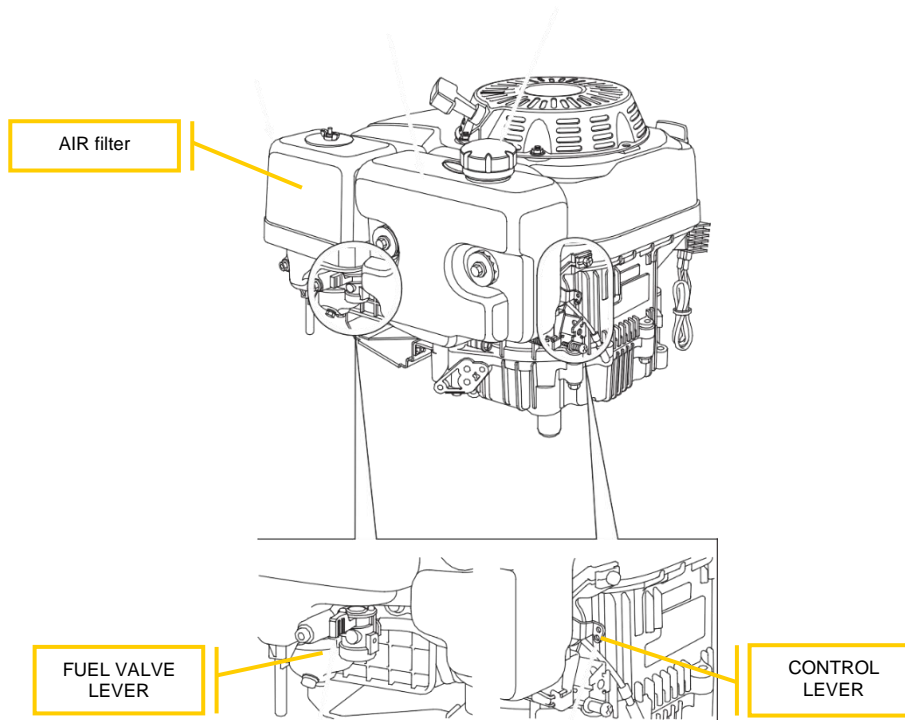
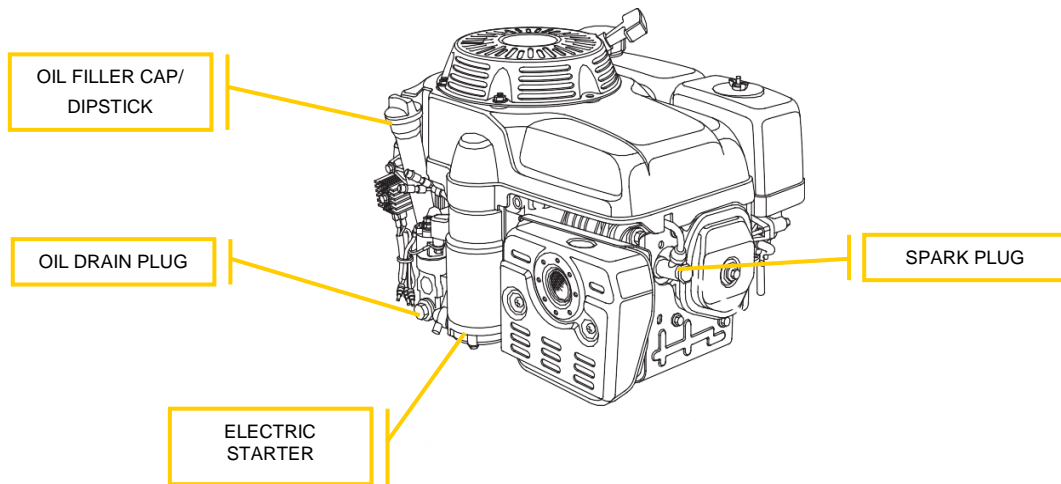

#### WARNING



Dust particles in the air or light explosive material (e.g. straw, grass, sawdust, etc.) must not accumulate in the engine and exhaust area. Inspect these places regularly and clean them before each shift, or more often if required. Before opening the engine cover, make sure there is no coarse dirt on it.

#### WARNING

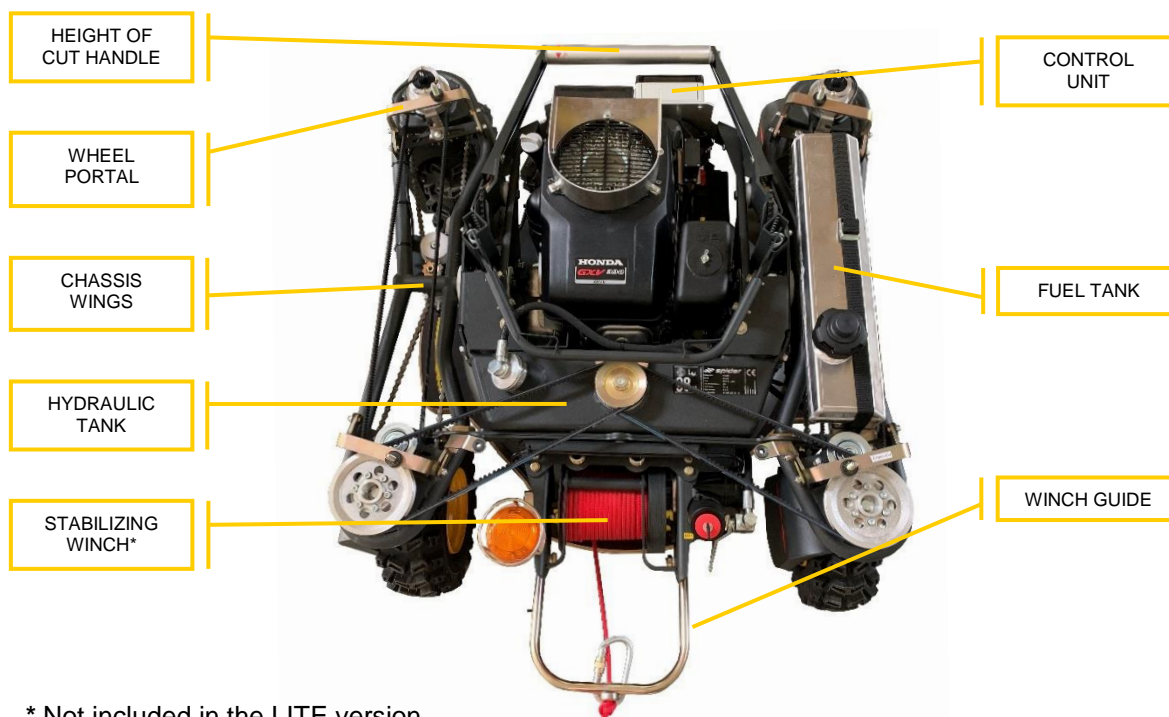

The engine has uncovered rotating parts. Switch off the engine before working in the engine compartment. Do not start the engine with the engine cover open.

**MOWER – SERVICE POINTS**

\* Not included in the LITE version

**To get access to the engine compartment and chassis wings:**

- 1) Place the mower on a level and solid surface.
- 2) Switch off the mower using the CENTRAL STOP button and remove the key. Switch off the remote control.
- 3) Unscrew the 4 nuts on top of the chassis wings covers (17 mm socket wrench with extension to prevent damage to the covers).
- 4) Remove engine and chassis wing covers.

**To get access to the cutting device:**

- 1) Place the mower on a level and solid surface.
- 2) Switch off the mower using the CENTRAL STOP button and remove the key.
- 3) Place the mower in [the vertical service position](#).
- 4) Remove the cutting blade (19mm socket wrench).
- 5) Remove the four bolts on the mowing mechanism cover (10 mm socket wrench).

**WARNING**

In the mowing mechanism area, the grass settles continuously. Make sure that the area is always clean.

## 8.5 GEOMETRY ADJUSTMENT

The geometry is adjusted mechanically. The mower operator evaluates whether the geometry needs to be adjusted or not.



If you do not have the necessary equipment and experience, have this work done by a specialist.



If the signal between the remote control and the machine is lost (eg a discharged remote control battery, by pressing the STOP button on the remote control or the CENTRAL STOP button on the machine), the mower drive and travel servomotors automatically return to their home position!

Always make sure that the remote-control battery is fully charged when working with the mower deck and when driving, so that the signal is not unexpectedly interrupted and the control rods and tensioner pulleys do not move. There is a risk of injury!

### GEOMETRY ADJUSTMENT PROCEDURE FOR SKID-STEERING MACHINES

- 1) Place the mower in [horizontal service position](#) so that the frame is in contact with the floor and the wheels are lifted free from the ground.
- 2) Hold down the skid-steering button until the wheels slightly deflect, then release the button - the wheels will return to the initial position (zero position). Turn off engine but keep remote control connected.
- 3) Remove the engine and side chassis covers.
- 4) Loosen the 2 screws on the sensor on the rear wheel.  
(3 mm Allen key).
- 5) Apply a straight bar to the wheel portals.
- 6) Turn the sensor gently to turn the wheels until they are parallel.
- 7) If one wheel is misaligned, loosen the 3 bolts on the portal sprocket  
(13 mm spanner). Then manually align the wheel until it is parallel with the other wheel on the same side.
- 8) Once the two wheels are parallel, tighten the bolts on the sensor and then the bolts on the rear sprocket.
- 9) Adjust the second side in the same way.
- 10) The machine is ready for use.

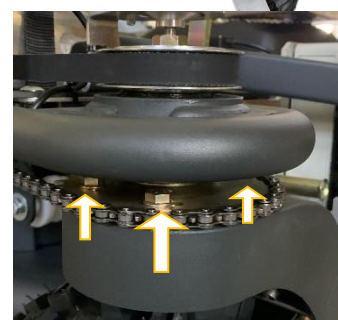



## GEOMETRY ADJUSTMENT FOR MACHINES WITHOUT SKID-STEERING

- 1) Place the mower in a horizontal service position so that the frame is in contact with the floor and the wheels are free from the ground.
- 2) Turn the wheels until one of the sides is parallel when a straight bar is pressed against the wheel portals. Leave the mower on with the engine off.
- 3) Remove the engine hood and the side cover that does not have the wheels aligned. (Make adjustments to the wheels on this side)
- 4) Loosen the 2 screws on the sensor on the rear wheel. (3 mm hex)
- 5) Place a straight bar against the wheel portals.
- 6) Gently turn the sensor until the wheels are parallel.
- 7) If one wheel is out of alignment loosen the 3 bolts on the portal sprocket (13 mm spanner). Then manually align that wheel.
- 8) Once the two wheels are parallel, tighten the bolts on the sensor and then the sprocket.
- 9) At this point, the wheels on both sides should be aligned check by applying the straight bar.
- 10) The machine is ready for further use.



## 8.6 ENGINE MAINTENANCE

Before starting any maintenance work on the mower, switch off the engine, press the CENTRAL STOP emergency button on the mower and on the remote control. To prevent the engine from starting unexpectedly, disconnect the (-) terminal on the battery. Always allow the engine to cool before performing maintenance. Maintenance may only be performed by properly trained personnel who have the necessary tools, implements, spare parts and professional skills. For repairs, maintenance and cleaning, follow the original engine operating instructions, which are part of this technical manual package.

### ENGINE OIL

#### Recommended oil

Use four-stroke engine oil that meets or exceeds SJ, SL, or equivalent API parameters.

**SAE 10W-30** is recommended for normal use.



#### WARNING

If you cannot provide enough engine oil for any reason, do not continue driving. Switch off the engine and consult a specialized service center. There is a risk of serious engine damage.

### OIL LEAK CHECK

Check the engine regularly for engine oil leaks. If you notice leaks, contact an authorized service center.

### OIL LEVEL CHECK

Ensure that the mower is on a level surface

- 1) Unscrew the pull-out cap with the dipstick and wipe it off with a service rag.
- 2) Insert cap/dipstick without screwing it into the oil filler neck.
- 3) Check the oil level shown on the dipstick
- 4) If the level is near or below the lower limit mark, top off the recommended oil to the upper limit mark.
- 5) Place the oil dipstick back in its place and tighten.

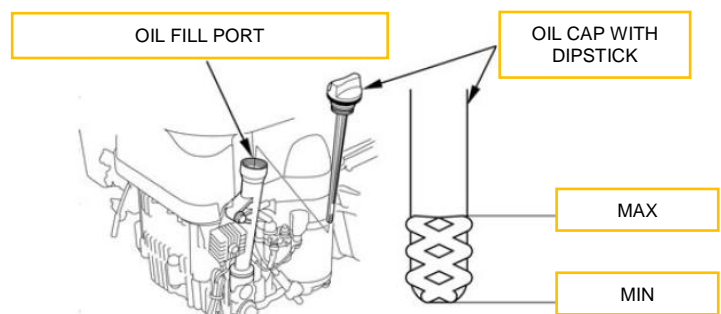

### ENGINE OIL CHANGE

Engine oil must be replaced at the intervals specified in the engine maintenance schedule. See also: [ENGINE MAINTENANCE SCHEDULE](#)



Drain the used oil when the engine is warm. Warm oil drains quickly and completely.

- 1) Place a suitable container below the engine to pour the used oil, then remove the oil filler cap/dipstick, oil drain plug and washer.
- 2) Allow the used oil to drain completely, then reinstall the oil drain plug and a new washer, and tighten the oil drain plug securely. Please dispose the used motor oil in a manner that is compatible with the environment. We suggest you take used oil in a sealed container to your local recycling center or service station for reclamation. Do not throw it in the trash, pour it on the ground, or pour it down a drain.
- 3) With the engine in a level position, fill to the upper limit mark on the dipstick with the recommended oil.
- 4) Screw in the oil filler cap/dipstick securely.

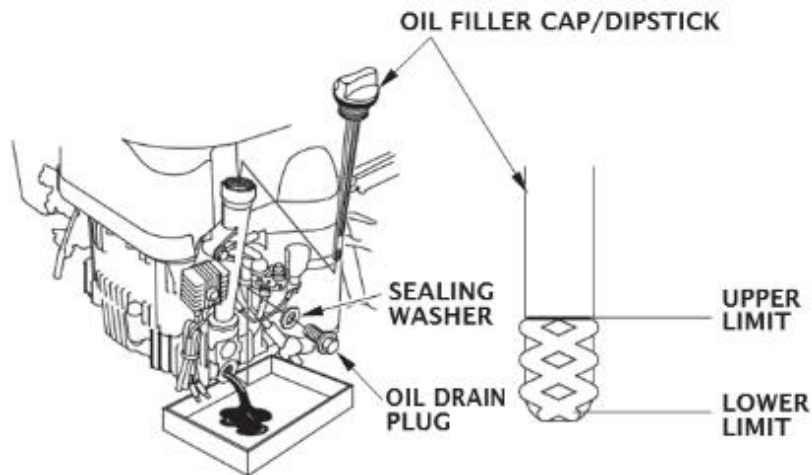

## ENGINE AIR FILTER

A dirty air cleaner will restrict air flow to the carburettor, reducing engine performance. If you operate the engine in very dusty areas, clean the air filter more often than specified in the MAINTENANCE SCHEDULE.



### ATTENTION

Operating the engine without an air filter, or with a damaged air filter, will allow dirt to enter the engine, causing rapid engine wear. This type of damage is not covered by the Distributor's Limited Warranty.



The air filter must remain dry in order to function properly. Never apply oil to it.

## CLEANING THE AIR FILTER

Remove the air cleaner cover and check the filter elements. Clean or replace clogged filter elements. Always replace damaged filter elements.

- 1) Unscrew the wing nut from the air filter cover, and remove the cover.
- 2) Pull out the air filter elements.
- 3) Remove the foam air filter element from the paper air filter element.
- 4) Inspect both filter elements and replace if damaged. Change the paper filter cartridge according to the MAINTENANCE SCHEDULE.
- 5) Clean the air filter elements if they are to be reused.

**Paper air filter element:** Tap the filter element several times on a hard surface to remove dirt, or blow compressed air [not exceeding 207 kPa (2.1 kg/cm, 30 psi)] through the filter element from the inside. Never try to brush off dirt; brushing will force dirt into the fibers.

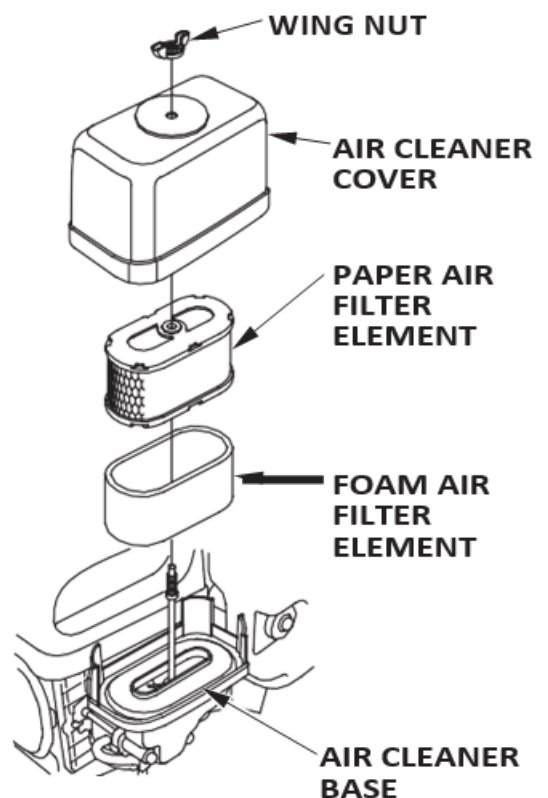

**Foam air filter element:** Clean in warm soapy water, rinse, and allow to dry thoroughly. Or clean in non-flammable solvent and allow to dry. Dip the filter element in clean engine oil, then squeeze out all excess oil. The engine will smoke when started if too much oil is left in the foam. Use a damp cloth to wipe away dirt from inside of the air filter bed and from the air filter cover. Make sure that no dirt gets into the air intake that leads to the carburetor.

- 6) Wipe dirt from the inside of the air cleaner case and cover using a moist rag. Be careful to prevent dirt from entering the air duct that leads to the carburetor.
- 7) Place the foam air filter element over the paper element, and reinstall the assembled air filter.
- 8) Install the air cleaner cover, and tighten the wing nut securely.

## SPARK PLUG

**Recommended Spark Plugs:** BPR5ES (NGK) or W16EPR-U (DENSO)



### ATTENTION

An incorrect spark plug can cause engine damage. For good performance, the spark plug must be properly gapped and free of deposits.

- 1) Disconnect the spark plug cap, and remove any dirt from around the spark plug area.
- 2) Remove the spark plug with a 13/16-inch spark plug wrench.
- 3) Inspect the spark plug. Replace it if damaged or badly fouled, if the sealing washer is in poor condition, or if the electrode is worn.
- 4) Measure the spark plug electrode gap with a wire-type feeler gauge. Correct the gap, if necessary, by carefully bending the side electrode.

The gap should be: 0.7–0.8 mm (0.028–0.031 in)

- 5) Install the spark plug carefully, by hand, to avoid cross-threading.
- 6) After the spark plug is seated, tighten with a 13/16-inch spark plug wrench to compress the sealing washer.
 

When installing a new spark plug, tighten 1/2 turn after the spark plug seats to compress the washer.

When reinstalling the original spark plug, tighten 1/8–1/4 turn after the spark plug seats to compress the washer.

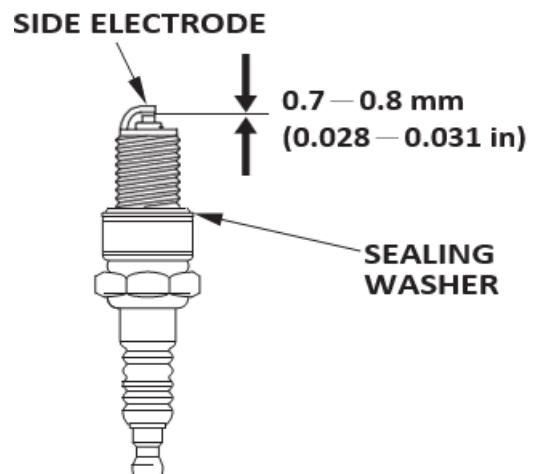
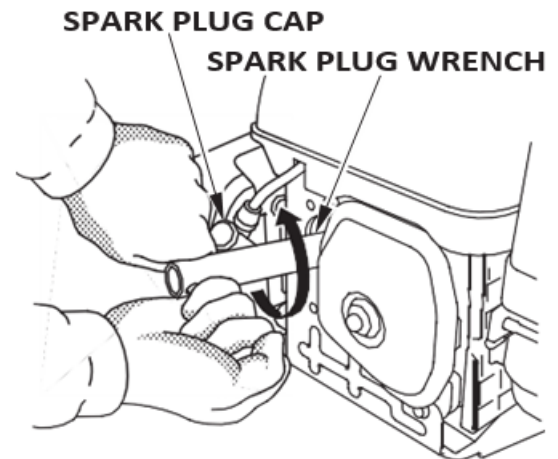

### ATTENTION

A loose spark plug can overheat and damage the engine. Overtightening the spark plug can damage the threads in the cylinder head.

- 7) Attach the spark plug cap to the spark plug.

## CLEANING THE ENGINE

Make sure that no dirt accumulates in the engine compartment. Pay special attention to the area of the exhaust where no flammable material must be present.

If the engine has been running, allow it to cool for at least half an hour before cleaning. Clean its surface, repair any damage to the paint and paint the areas prone to corrosion with a thin layer of oil.



### WARNING

When spraying with a garden hose or when washing with pressurized water, water may enter the air cleaner or muffler opening. Water, if it enters the air filter or muffler, can penetrate the cylinder and damage it.

## 8.7 FUEL SYSTEM

### CLEANING THE FUEL TANK

While the mower is in use, dirt may accumulate in the fuel tank, which may cause the fuel system to clog up when the mower is operating. The tank may only be emptied by suctioning petrol, taking all precautions when handling fuel. The fuel tank venting system is integrated into the tank cap, where it is ended by a flip valve closing the venting system when the mower is overturned.



### WARNING

Do not smoke or handle open flames near gasoline when working with gasoline.

### DRAINING THE FUEL TANK

- 1) Place the petrol container under the carburetor and use a funnel to prevent petrol from spilling.
- 2) Unscrew the drain plug, remove the seal and drain the fuel from the carburetor tank into the petrol canister.
- 3) Move the fuel valve lever to the ON position. In this way, the fuel tank is drained through the carburetor tank.
- 4) After draining the carburetor tank and fuel tank, install the seal, screw in the drain plug and tighten it firmly.

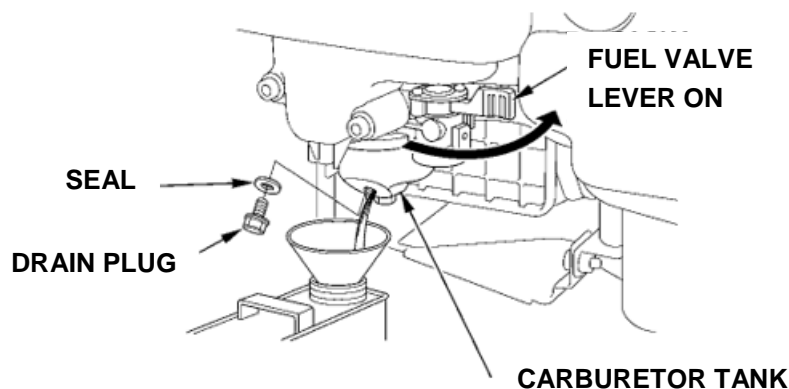

### REPLACING THE FUEL FILTER

The fuel filter is replaced every 200 hours of operation.

- 1) Ensure safe operation of the mower
- 2) Turn off the engine and mower.
- 3) Arrange access to the engine area.
- 4) Remove the old fuel filter.
- 5) Install new fuel filter.

## 8.8 MOWING BLADE

### Check the condition of the blade regularly:

- Cannot bear traces of damage such as bending, or other deformations.
- It must be securely fastened to the blade hub with fixing screw.
- Must be sharp.
- The fastening screws must be free of any damage.

### If the blade is damaged, it is forbidden to:



- Straightening the blade
- Heating the blade
- Welding and surfacing the blade
- Reinforcement and other interventions in its construction

## CHANGING THE BLADE

- 1) Place the mower on a firm, level surface.
- 2) Stop the engine, press CENTRAL STOP on the controller and the mower.
- 3) Disconnect the battery.
- 4) Raise the mower to the service position and secure it against tipping over.
- 5) Loosen the blade retaining screws. Remove the screws and washers. Note that when removing the screw, the blade may fall to the ground.
- 6) Follow the reverse procedure when mounting the blade.



- Always check the tightening of the screws when mounting the knife.
- Wear protective gloves.

## BLADE INSPECTION AND GRINDING

### To check the blade geometry:

- the blade must not be bent
- never straighten a bent blade, USE NEW!
- the ends of the blade must be flush (test whether the whole surface is on a flat surface)

### Grinding:

- grind **only the 100 mm sharp part** of the blade
- grinding is carried out at an **angle of 45°**
- grind **both sides** of the knife **evenly** (up to a **maximum depth of 12 mm**)
- after sharpening **check the blade balance!**

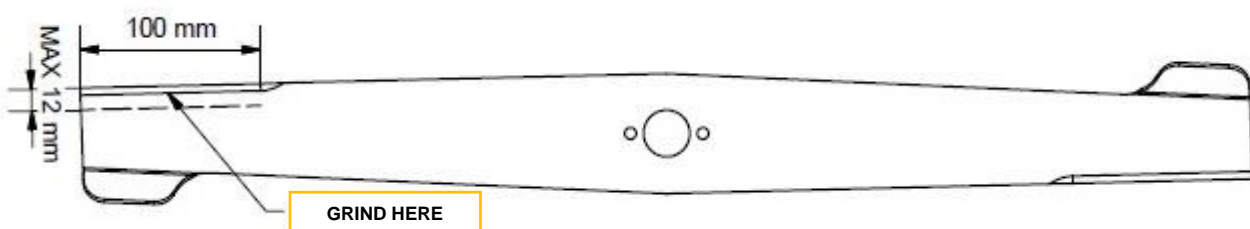

## 8.9 HYDRAULIC SYSTEM

Maintenance of the hydraulic drive must be done by properly trained service personnel.



### WARNING

Damaged hoses can cause fatal accidents. Check the hoses regularly. Do not use the mower if the hoses or their fittings are damaged.



### WARNING

Thin jets of fluid escaping from the nozzles at high pressure can penetrate the skin. Protect your face and hands from fluid under pressure and wear personal protective equipment. Hold cardboard where you suspect a leak, and then check for any traces of hydraulic fluid. Seek medical advice immediately if hydraulic fluid penetrates the skin.

### CHECK THE HOSES REGULARLY FOR:

- Damaged hose ends
- Worn external covers
- Concave outer covers
- Tangled or crushed parts
- Stripped reinforcement in outer covers
- Extruded hose fittings
- Worn casing or hose guard breaks

Exchange of the hydraulic hoses must be done only by the authorized service center.

### CHECKING FOR OIL LEAKAGE

Check the hydraulic hoses for damage. Check all hydraulic functions. In particular, check the speed of operation, vibrations and abnormal sounds. Do not use the mower where one or more of these defects appear.

### HYDRAULIC OIL LEVEL CHECK

- 1) Make sure the mower is on a level surface.
- 2) Stop the engine and allow to cool off.
- 3) Remove the engine and side covers.
- 4) Remove the hydraulic oil tank cap.
- 5) Visualize the oil level. The oil level must reach at least (A = 10mm) from the top of the tank.
- 6) If the level is below the specified mark, add the recommended hydraulic oil.
- 7) Tighten hydraulic tank cap and place covers back on machine.



## 8.10 HYDRAULIC STABILIZING WINCH\*

\* Not included in the Cross Liner Lite version

### ROPE MAINTENANCE

Before each shift, check the condition of the rope, especially if you have been working in terrain where unwanted objects, sharp edges, etc. were present.

After 20 hours of operation, pull the entire rope out of the winch and check its condition thoroughly for any damage.



### WARNING

If the surface layer of the rope is damaged, replace the entire rope or shorten it if its shortened length suits you. The use of a damaged rope is strictly prohibited.

**WARNING**

Do not directly expose the tow rope to hot / warm objects.

**MOUNTING THE CARABINER**

Lead the rope through the lashing ring, write an eight figure around the fixed end and thread it through as shown in the picture.

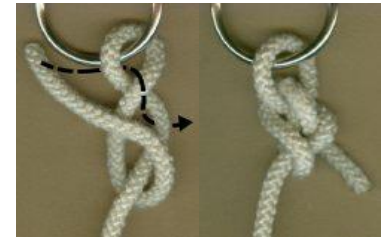
**MOUNTING THE ROPE**

Mounting the new rope must be done only by the authorized service center.

**CLEANING THE WINCH**

After each shift, remove any dirt from the surface of the winch as well the hydraulic hoses. Remove any dirt by brushing with a broom. Do not use pressured water. If water is used, the sprocket mechanism should be dried immediately. Do not use gasoline or other petroleum products for cleaning.

**8.11 ELECTRICAL SYSTEM****CONTROL UNIT – MODES**

The premium version control unit works in 3 modes:

- Normal Mode
- Emergency Mode
- Service Mode

The LITE version control unit works in 2 modes:

- Normal Mode
- Service Mode

**Normal mode**

Under normal conditions, the mower operates in normal mode. The mower fully responds to all remote-control inputs. All safety functions are switched on.

Normal mode is exited if a serious error occurs or when service mode is initiated.

**Emergency mode**

In the event of a serious fault defined as "Shutting down the machine" (see section CONTROL UNIT - ERROR CODES), the mower can be put into so-called emergency mode by pressing the red control button (service button) on the control unit. When the emergency mode is started, the red button flashes. (This mode is only possible on a Premium control unit with a display.)

The emergency mode is only used when it's necessary to transport the mower to a safe place where it is possible to perform adequate service operations. The mower cannot be started during machine emergency mode.

When the emergency mode is started, the wheel rotation automatically returns to the initial zero position. However, if the machine error is caused by one of the turn servomotors, the wheel rotation will not return to the home zero position and the machine cannot steer in emergency mode.

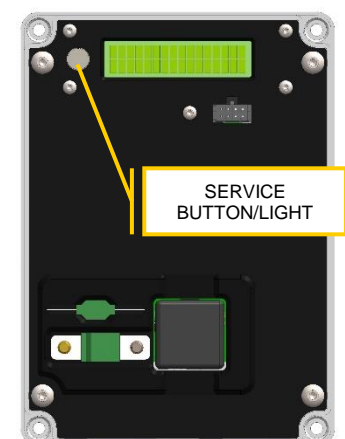
**WARNING**

Unexpected machine behavior can occur in emergency mode. The operator must keep in mind that the machine can be dangerous to its surroundings in emergency mode! By initiating emergency mode, the operator assumes full responsibility for the consequences caused by operating the machine.

Danger of injury!



## Service mode

Service mode is used to set up and adjust the mower. In service mode, the mower behaves the same as in normal mode, but has the following safety functions suppressed:

- Mower tilt detection
- Radio signal loss detection

During service mode, the tilt alarm does not start automatically, and mower safety systems are switched off (mowing system can still be engaged).

### Starting the service mode:

- 1) Switch off the mower using the EMERGENCY STOP button.
- 2) Remove the protective plexiglass from the control unit.
- 3) Insert the service key into the service connector.
- 4) Switch the mower on by releasing the EMERGENCY STOP.
- 5) Perform the intended service.

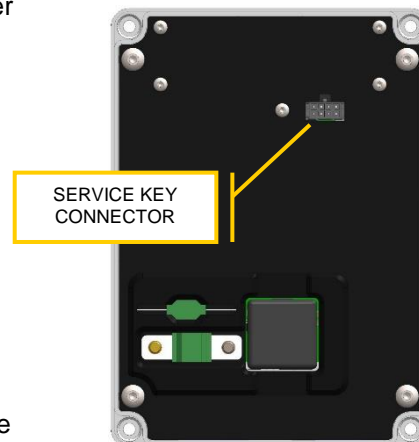

Front panel of the control unit without protective plexiglass

### Switching off service mode

- 1) Switch off the mower using the EMERGENCY STOP button on the mower.
- 2) Remove the service key from the service connector.
- 3) Install the protective plexiglass cover on the control unit.



#### WARNING

During service mode, the safety functions are disabled, so the machine can be dangerous to its surroundings. It is the operator's full responsibility for operating the machine in this mode!

## CONTROL UNIT - SERVICE INTERVALS

The premium control unit alerts the user of upcoming maintenance services:

### Engine oil change

- After the first 20 operating hours / first month
- Every other 100 operating hours / every six months

### Hydraulic oil change

- Every 200 operating hours / every year

The upcoming service interval is shown on the display with the "S" symbol in the right part of the screen

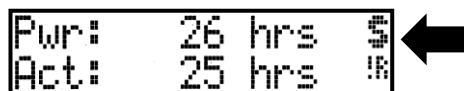

### To reset the service interval, proceed as follows:

- 1) Remove the protective plexiglass from the control unit.
- 2) Press and hold the control button on the control unit. (The mower must be switched on, the control button flashes green)
- 3) The message:

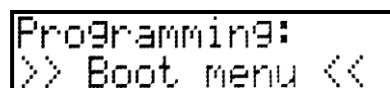

- 4) To switch between items, briefly press the control button.

```
Programming:
  Motor oil time
```

```
Programming:
  $ Hydraulic time
```

- 5) To reset the service interval, press and hold the control button.  
6) To return to the main menu, hold down the button in the "EXIT MENU" item.

```
Programming:
  EXIT MENU
```

- 7) Install the protective plexiglass on the control unit.

## CONTROL UNIT - ERROR CODES

If any error is detected by the self-diagnostics, an error code will be displayed on the second line of the display. If there are several errors, they are automatically shown on the display one after the other. The error code consists of a so-called prefix and an error code.

```
Pwr:      2 hrs
Err #1:  00-104%
```

↑      ↑  
Prefix   Error Code

The prefix indicates on which component the error occurred:

Prefix	Module
00	Control unit
31	Left wheel steering servomotor
32	Right wheel steering servomotor
35	Travel servomotor
36	Mower servomotor

The error code provides information about the type of error that occurred:

Error code	Error description	Error severity
000	The module has an error or cannot be paired	Warning on the display
001	Critically low supply voltage	Shutting down the machine
002	Supply voltage drop	Warning on the display
003	Critical current overload	Shutting down the machine
004	Current increase detected	Warning on the display
005	Temperature sensor fault	Shutting down the machine
006	Critical overheating of the component	Shutting down the machine
007	Elevated component temperature	Warning on the display
010	Unexpected shutdown of the power stage	Shutting down the machine
011	Power stage undervoltage detected	Shutting down the machine
012	Power stage charge pump malfunction	Shutting down the machine
013	Power stage gate driver malfunction	Shutting down the machine
014	Power stage overcurrent detected	Shutting down the machine
015	Power stage overheated	Shutting down the machine
100	Date and time not set	Information on the display
101	Low battery voltage	Warning on the display
102	Accelerometer not working or readout error	Shutting down the machine
103	High tilt angle warning	Warning on the display with audible alarm
104	Critical tilt angle cut off	Shutting down the machine
106	Control unit overheating	Shutting down the machine
107	RF signal lost	Display warning with audible alarm

\* Shutdown of the machine = serious error, the mowing unit and the combustion engine of the machine will be switched off, in this case contact an authorized SPIDER service center.

## CHARGING THE RC BATTERY

1. Slide the battery from the controller
2. Connect the charger to the car cigarette lighter socket.
3. Insert the battery into the charger (the green and orange LEDs lights are on and the battery is charging).
4. When charging is complete, the orange LED turns off.



### NOTE:

Leave the battery in the charger as needed (the charger monitors the battery and does not overcharge the battery). If the battery used in the controller is low, replace it with a charged battery.

## FUSES

Electrical circuits are protected by a fuse (32V, 40A). If the fuse blows, find out why this occurred before installing a new one.

The fuse and spare fuse are located in the control unit.

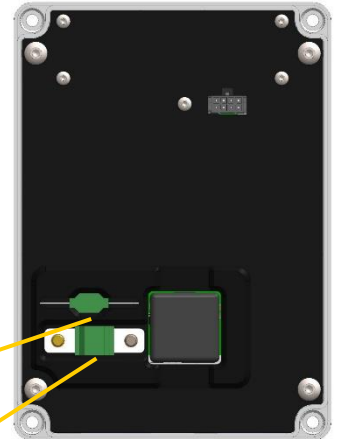

### WARNING

Use only fuses with the specified ampere rating. This will prevent damage to the electrical system.

SPARE FUSE

FUSE

## BATTERY MAINTENANCE

Check the battery cleanness at regular intervals.

Keep terminals and clamps clean of dust and corrosion. Terminal corrosion may affect battery performance and may pose a safety hazard. If you notice corrosion, disconnect the battery, loosen and remove the clamps, and remove the corrosion by spraying the terminals and clamps with a weak solution of baking soda and water (sodium bicarbonate). Apply the anti-corrosion emulsion again before reconnecting the clamps. Always keep proper records of maintenance.

**DO NOT REMOVE THE BATTERY SAFETY VALVE UNDER ANY CIRCUMSTANCES AND NEVER ADD WATER.**

### HOW TO DISCONNECT THE BATTERY

- 1) Press the Central Stop on the mower and power off the RC.
- 2) Disconnect the battery terminals. First, disconnect the ground terminal (-).

### HOW TO CONNECT THE BATTERY

- 1) Connect the battery terminals. Connect the ground terminal (-) last.
- 2) Secure the battery against movement using a tie-down strap

## BATTERY STORAGE

To achieve maximum battery life, we recommend storing a fully charged battery at a temperature of around 10 ° C. Recharge the battery approximately every two months, as it will self-discharge during storage.

## BATTERY TESTING

The best and easiest way to test the battery is to use a voltmeter or a multimeter to measure the resting voltage. If you know the exact voltage, use the table below to determine the charge.

Make sure that the battery is fully charged so it can provide enough starting energy. The recommended charging current is 10% of the nominal capacity in amperes, i.e. 1.0A [ampere]). To ensure long life, we recommend that the battery be fully charged before installation.

Resting voltage	Charge status	Action required
More than 12,6 V	100 %	No action is required
12,40 – 12,54 V	70 %	No action is required
12,24 – 12,40 V	50 %	Charge the battery
11,88 – 12,18 V	20 %	Charge the battery immediately
Less than 11,8 V	0 %	Battery must be replaced

## 8.12 NEUTRAL POSITION ADJUSTMENT

During the use of the mower, the neutral position of the servomotor may be off-center, and the mower will start to drive automatically. In this case, it is necessary to adjust the neutral position.

### PROCEDURE:

- 1) Place the mower on a flat firm surface.
- 2) Raise the mower to the [horizontal service position](#) so that the machine mowing deck touches the ground and the wheels are clear off the ground.
- 3) Start the engine.
- 4) Loosen the lock nuts (13mm wrench) on the traction actuator linkage.
- 5) Adjust the tightening of the joints so that the wheels do not move forward or backward once in the neutral position.
- 6) Tighten the lock nuts.



## 8.13 DRIVE BELTS AND STERING CHAINS

### HYDRAULIC PUMP AND MOWING UNIT BELTS



#### WARNING

Make sure the engine is switched off before changing the belt. Remove the key from the CENTRAL STOP before checking the belt tension.

The mower drive and drive system are equipped with maintenance-free V-belts. The mowing unit is lowered on the remote control, where the switch is set to the on position - the pulley controlled by the servomotor tightens the belts of the mowing unit and thus the blade is lowered. When the mowing unit is switched off, the pulley is adjusted - the belts are released from engagement and the driven pulley is braked by the brake belt, thus stopping the blade.

#### INSPECTION

- 1) Place the mower on a level and firm surface. Remove the key from the CENTRAL STOP button.
- 2) Move the mower to the vertical service position.
- 3) Remove the blade (19 mm wrench).
- 4) Loosen 4x screw (10 mm wrench) and remove the cutting deck cover.
- 5) Check the pulley's metal brake strip for wear, check the belts for wear, and check if the nuts and bolts are tightened properly.
- 6) If the tension is insufficient or the belts and the braking strip are worn, have the belt replaced or the tensioning mechanisms adjusted by an authorized dealer or service center.

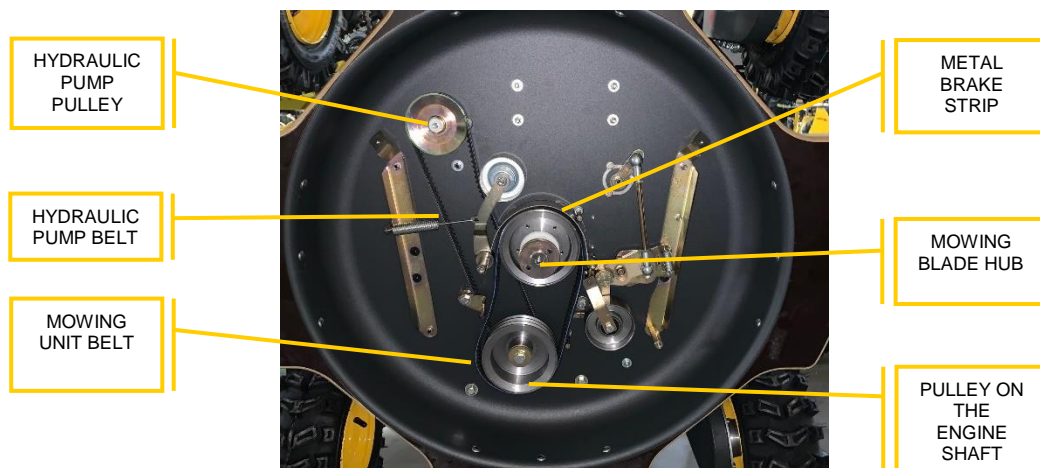

## DRIVE BELTS AND STEERING CHAINS

### INSPECTION

- 1) Place the mower on a flat and firm surface, press CENTRAL STOP on both the controller and the mower and remove the key.
- 2) Remove the engine cover and the side covers (4x screw - use a 17 mm socket with an extension).
- 3) Check the chain tension by applying a slight thumb pressure in the middle of the branch. Deflection should be within 2 cm.
- 4) Inspect both wings.

### TENSIONING

#### • DRIVE BELT

Tensioning is carried out with the belt tensioner (Loosen the nut, tension the belt and again tighten the nut.)

#### • STEERING CHAIN

Tensioning is carried out with the chain tensioner.

TIP: For better access to belt and chain tensioner on the left, unlock the tank strap and tilt the tank. Carry out maintenance on the belt and fasten the tank properly back in place. Make sure that no fuel leaks when handling the tank.

#### • TRACTION DRIVE BELT

These are maintenance-free belts, in case of excessive tension, have the belt replaced by an authorized service center.

### EXCHANGE

Damaged and worn chains / belts must be replaced immediately. Have the replacement carried out by an authorized service center.

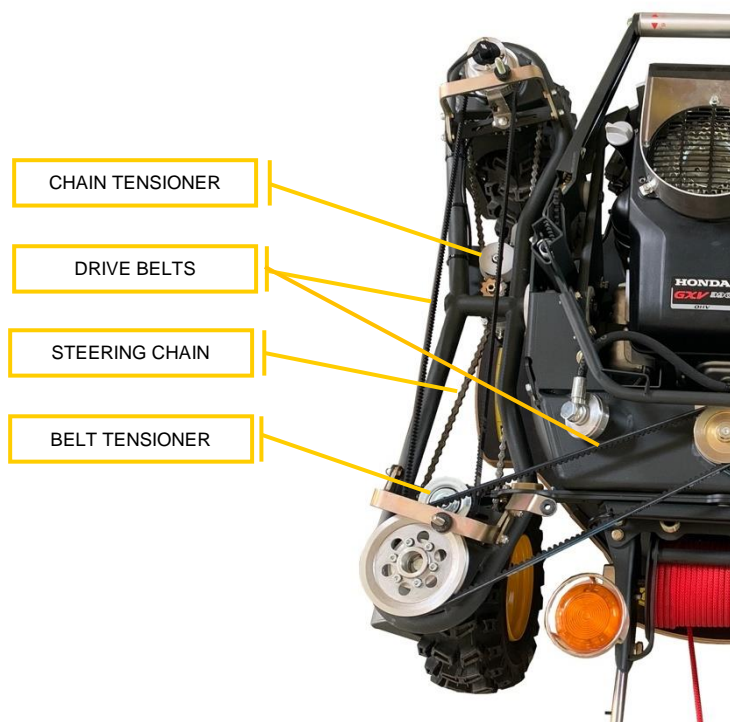

## 8.14 WHEEL PORTALS

The wheel suspension drive contains an automatic tensioning segment and therefore does not need to be adjusted. If the chains need to be replaced, contact an authorized service center.

## 8.15 LUBRICATION

Apply a reasonable amount of lubricant to the parts to be lubricated. Excessive amounts of lubricant cause leakage and contamination of the mower and the environment. Insufficient quantity requires more frequent lubrication and can lead to damage.

We recommend using Interflon chain spray for lubrication. The chain for the steering of the wheels needs to be lubricated regularly. For post-season maintenance, also lubricate the gear in the winch body and stroke (see pictures below)

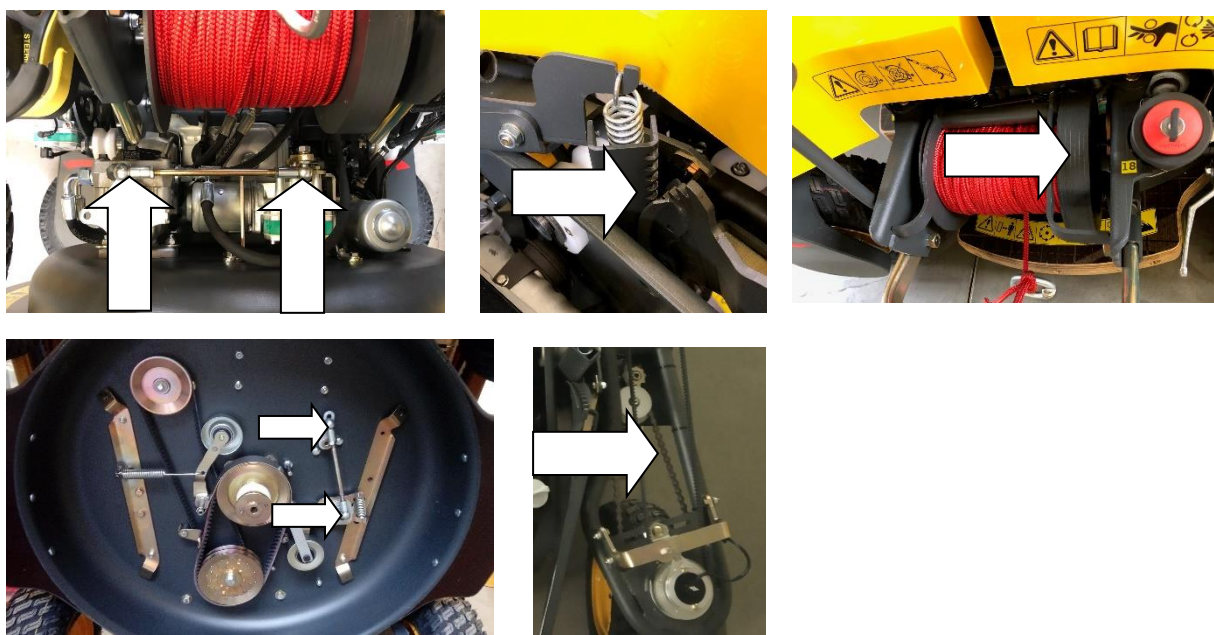

## 8.16 TYRE PRESSURE

Observe the recommended tyre pressure. Other values may adversely affect handling, especially on slopes. In some cases, you may also lose control of the mower.

### Recommended tyre pressure:

Turf tires: max. 200 kPa – 2,0 bars

X-track tires: max. 150 kPa – 1,5 bars.

## 8.17 TYRE REPLACEMENT

- 1) Place the mower on a flat and solid surface.
- 2) Turn the wheels so that the mounting nuts are accessible from the outside.
- 3) Stop the engine, remove ignition key from the CENTRAL STOP button.
- 4) Secure the machine against movement.
- 5) Lift the mower and place a service block under the mowing deck. (Ensure that the machine is securely supported before working on it.)
- 6) Loosen the retaining nuts, remove the tyre. (17mm)
- 7) After replacing the tire, proceed in the reverse order.

## 8.18 MOWING HEIGHT ADJUSTMENT

Keep rack and lift lever parts clean, undamaged and without excessive play.

The control cords must be slightly overstretched. Replace the cord if it is damaged.

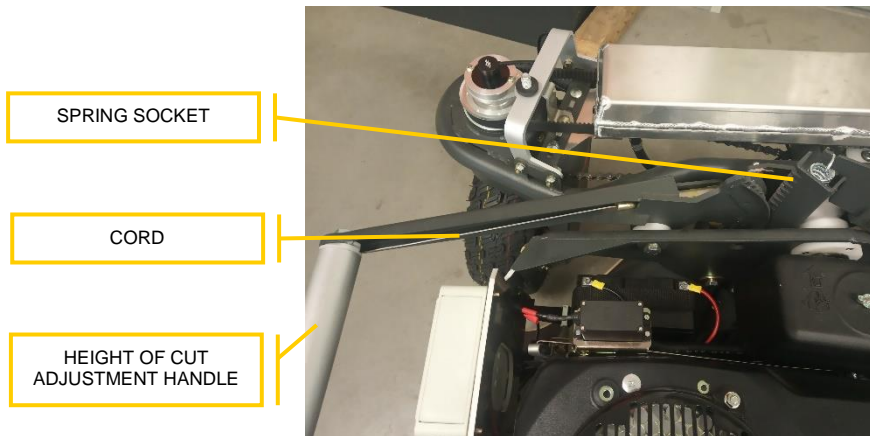



## 9 TECHNICAL DATA

### 9.1 FLUIDS, LUBRICANTS AND FILLING VOLUMES



#### WARNING

In the event of any unauthorized fuel types (or their equivalents) being used at any time, the producer disregards any liability for engine damage or failure.

Item	Fluid/Lubricant	Volume
Fuel tank	Petrol 95 octane	3,5 l
Engine oil	SAE 10W-30 API classification SJ, SL or equivalent	1,1 l*
Hydraulic oil	ATF Q8 AUTO14	3,5 l*
Wheel portal	Mobilux EP 004	0,3l
Lubricating oil	Interflon (or any Teflon based lubricant is recommended)	

\* When refilling the operating fluids, always respect recommended volumes.

### 9.2 TECHNICAL DATA

The mower is designed to operate at atmospheric temperatures between -20° C and 46° C.

Parameter	Measure	CROSS LINER	CROSS LINER LITE
Dimensions (l x w x h)	mm	980 × 1110 × 600	
Mowing width	mm	650	
Height of cut	mm	45–110	
Weight	kg	175	163
Speed	km/h	0–6	0–4,8
Cutting deck	-	Single rotating blade 650 mm	
Hydraulic drive pump	-	Hydro Gear 6 ccm	
Hydraulic drive motor	-	Sauer Danfoss OMM 32	M + S Hydraulic
Drive	-	4 × 4	
Wheels	inch	13×5.00-6 (X-Track)	13×5.00-6 (TURF)
Battery		12 V, 10 Ah, gel	
Fuel	-	Unleaded petrol – natural 95	
Fuel tank volume	l	3.5	
Motor	-	Air cooled 4-stroke single valve Honda GXV390	
Cubic capacity	cm <sup>3</sup>	389	
Performance	kW	7,6	
Engine Rpm	1/min	2850	
Ignition	-	Electronic	
Starter	-	Electric	
Winch rope - diameter	mm	6	Not included
Winch rope - length	m	25	
Minimum carabiner strength	kN	20	
Winch hydro motor		Sauer Danfoss OMM 32	
Frequency range EU and USA	MHz	(863-870) EU - (915-928) US + Australia	

## **NOISE EMISSIONS**

The mower emits the following noise: Sound power LWA = 95,8 dB

Guaranteed sound power level LWA = 98 dB

The measurement was carried out according to ISO 3744

# 10 TROUBLESHOOTING

## 10.1 MOWER TROUBLESHOOTING

Failure	Probable cause	Repair
Engine doesn't start	Travel joystick is not in the neutral position	Move joystick to the neutral position
	The mower blade lever is in the "on" position	Move mower blade lever to the "off" position
	Pressed CENTRAL STOP button	Release the CENTRAL STOP button by turning it
	Empty fuel tank	Refuel
	Discharged battery in the RC	Recharge the battery / replace with the charged battery
	Discharged battery in the mower	Recharge the battery
	Disconnected battery	Check/exchange harness
	Spark plug doesn't work	Clean / replace the spark plug
	Fuel filter clogged	Exchange filter
	No connection between the controller and receiver	Check the receiver, move closer to the mower
	Electricity wire disconnection	Check the connection/contact your dealer
	Lack of hydraulic oil	Add oil
	Not enough engine oil	Add oil
Mower drive is not enough or slow	Overheated oil	Clean the cooling fan, wait until the system cools down
	Lack of hydraulic oil	Add oil
	Loose hydraulic drive belt	Tighten / Exchange
	Clogged hydraulic oil filter	Exchange
	Wear of the hydraulic circuit components	Exchange
	Worn V belts	Exchange
Mower does not drive up the slope	Not sufficiently tightened V belts	Tighten
	Drive servo malfunction	Exchange
	Worn V belts	Exchange
Mower vibrates when started	Blade is loose	Change the blades securing bolt and properly tighten
	Damaged or unbalanced blade	Exchange blade
	Blade carrier shaft is bent	Change the shaft
Cutting quality not satisfactory	High mowing speed	Slow down
	Blade is not sufficiently sharp	Sharpen or change blade
	Wet grass	Wait until the grass is dry
	Overgrown grass	Mow grass that is at most three times higher than the stubble height; we recommend mowing the grass, let the mow grass to dry out and mow it again
The cut grass is caught inside the mowing deck	Wet grass	Wait until the grass is dry
Not able to change the cutting height	Adjusting cords are loose	Tighten or replace
Not able to turn on the blade	Loose cutting belts	Check the condition of the belts or replace / consult a service center
Not able to turn the blade off	Worn or non-trimmed mower deck drive elements	Consult a service center

## 10.2 WINCH TROUBLESHOOTING

Failure	Probable cause of failure	Repair
The drum is not rotating	Lack of oil in the hydraulic system of the machine	Add hydraulic oil
Jerking motion of the drum	Lack of oil in the hydraulic system	Add hydraulic oil
The drum rotates only until the oil gets warm	Low engine speed	Increase the engine RPM to maximum
	Worn hydraulic motor	Replace the hydraulic motor
The winch is too noisy	Worn bearings of the winch drum	Replace the bearings

## 10.3 REMOTE CONTROL TROUBLESHOOTING

The table below lists malfunctions that are signaled by LEDs on the Transmitting Unit and the solution to those malfunctions. If the problem persists after attempting the suggested solution, contact the support service of the Machine Manufacturer.

Failure	Probable cause	Repair
The green LED blinks fast. The red LED <sup>1</sup> blinks for 3.5 minutes.	The battery is not sufficiently charged or the Transmitting Unit has been on for eight hours <sup>2</sup> .	The battery needs to be replaced with a charged one
The green LED repeats one of the following sequences: ONE or TWO blinks and a pause. The red LED <sup>1</sup> blinks for 3.5 minutes.		
The green LED repeats the sequence: three blinks and a pause. The red LED <sup>1</sup> blinks for 3.5 minutes.	The Transmitting Unit has been on for eight hours <sup>2</sup>	You need to switch off the Transmitting Unit and start the Radio Remote Control again.
The green LED is off. The red LED <sup>1</sup> has ONE very long blink.	The Transmitting Unit does not work correctly.	Contact the support service of the Machine Manufacturer.
At Radio Remote Control start up, the green LED is off and the red LED <sup>1</sup> has ONE long blink <sup>3</sup> .	The STOP pushbutton is pressed.	Unlock the STOP pushbutton.
At Radio Remote Control start up, the green LED is off and the red LED <sup>1</sup> has TWO long blinks <sup>3</sup> .	The Transmitting Unit does not work correctly.	Contact the support service of the Machine Manufacturer.
At Radio Remote Control start up, the green LED is off and the red LED has THREE long blinks <sup>3</sup> .	The battery is very low.	The battery needs to be replaced with a charged one
At Radio Remote Control start up, the green LED is off and the red LED <sup>1</sup> has FOUR long blinks <sup>3</sup> .	The SAFETY command is activated	Bring the actuators to the rest position.
At Radio Remote Control start up, the green LED is on and the red LED <sup>1</sup> has ONE to FOUR long blinks and some short blinks <sup>3</sup> .	At least one of the actuators corresponding to commands is activated.	Bring the actuators to the rest position. If necessary, it is possible to identify the activated command

<sup>1</sup>. Whenever the red LED illuminates, the acoustic signal device activates.

<sup>2</sup>. After this signal, the Transmitting Unit switches off.

<sup>3</sup>. Press START pushbutton and hold it down until the Transmitting Unit automatically switches off.

Whenever the red LED lights up, the acoustic signaling device is activated.

# 11 WARRANTY CONDITIONS

## LIMITED WARRANTY FOR NEW SPIDER EQUIPMENT

**GENERAL PROVISIONS** – The warranties described below are provided by DVOŘÁK – svahové sekačky s.r.o. (“Spider”) to the original purchaser of new equipment from Spider or authorized Spider Distributors/Dealers. Under these warranties Spider will repair or replace, at its opinion, any covered part which is found to be defective in material or workmanship during the applicable warranty term. Warranty service must be performed by a Distributor/Dealer or service center authorized by Spider to sell and/or service the type of equipment involved, which will use only new or remanufactured parts or components furnished by Spider. Warranty service will be performed without charge to the purchaser for parts and labor. The purchaser will be responsible, however, for any service call and/or transportation of product to and from the Distributor’s/Dealer’s or service center’s place of business, for any premium charged for overtime labor requested by the purchaser, and for any service and/or maintenance not directly related to any defect covered under the warranties below, including the necessity to clean the machine.

1. Spider provides Warranty:
  - 36 months for the Distributor/Dealer from the day the Product was delivered to the Distributor/Dealer
  - 24 months/800 working hours, whichever happens first, for the Customer after purchase and registration of the following products: Spider CROSS LINER, Spider ILD01, Spider ILD02, Spider 2SGS, Spider 3RIDER.
  - 12 months/400 working hours, whichever happens first for the Customer after purchase and registration of the following product: Spider CROSS LINER LITE when used commercially. For any natural person the warranty has to comply with local legislation.
  - 3 months for new Spare Parts delivered outside the Product Warranty from the day these were delivered to the Customer, but only under the condition that these were installed and mounted by an authorized service Distributor/Dealer. Otherwise, the Warranty is forfeit.
  - For new spare parts delivered under Warranty the Warranty period expires together with the Warranty period of the whole Product
2. The Distributor/Dealer is obliged to ensure performance of warranty inspections on the Product as prescribed in the Operator’s Manual.
3. In order for a warranty claim to be acknowledged, the purchaser must have had all prescribed warranty inspections performed and recorded.
4. In case of defects reclaimed by the Customer in terms of the warranty period, the Distributor/Dealer assesses and determines whether this concerns a defect in the warranty period, which can be acknowledged (acknowledged warranty) or not and ensures repairs are carried out.
5. If the Distributor/Dealer assesses the defect as one that can be acknowledged (acknowledged warranty), they are obliged to request in writing that Spider acknowledges such warranty repair at the latest within one month after the end of the month in which such warranty repair was performed. This can only be done through a standard “Warranty Claim Report” form. Such request will include all information about the method of assessment and solution of the warranty (description of defect, identification of defect, description of repair, list of defective parts, hourly work by the service center, specification of costs for repair, photo/video documentation of the repaired part). Spider is obliged after investigation, to make a decision on this request as whether to acknowledge the warranty or not.
6. Spider will make a decision about the acknowledgement of the warranty claim without unnecessary delay, latest within 60 days since the warranty claim is filed.
7. If the warranty is acknowledged, Spider will write out a credit note to the Distributor/Dealer for costs connected with the warranty repair – i.e. the cost of spare parts and the hourly rate for service work according to the valid repair norms.
8. Spider is entitled to reject such warranty claim if the warranty was acknowledged by the Distributor/Dealer in conflict with the warranty conditions. In such a case, Spider is not obliged to reimburse the Distributor/Dealer for costs for performance of such warranty repair work.

9. Acknowledged warranty repairs of commercial models (Spider CROSS LINER, Spider ILD01, Spider ILD02, Spider 2SGS, Spider 3RIDER) up to the level of EUR/USD 100.00 (one hundred EUR/USD) per case are not covered by Spider, costs connected with such repairs are covered by the Distributor's/Dealer's profit margin.
10. The Distributor/Dealer is obliged to ensure clear marking and storage of damaged spare parts, which were replaced under warranty for the period of min. 12 months, as well as of all-important documents pertaining to such warranty repair.
11. The selling Distributor/Dealer has no authority to make any warranty, representation, condition or promise on behalf of Spider, or to modify the terms or limitations of this warranty in any way and makes no warranty on any other item unless it delivers to the purchaser a separate written certificate specifically warranting the item.
12. Spider is not responsible for the following: (1) Used equipment; (2) Any equipment that has been altered or modified in ways not approved by Spider, including, but not limited to, setting injection pump fuel delivery above Spider specifications; (3) Depreciation or damage caused by normal wear, lack of reasonable and proper maintenance, failure to follow operation instructions, misuse, lack of proper protection during storage, or accident; (4) Any repairs done by the Customer; (5) Normal maintenance parts including blades, hydraulic hoses, belts, bearings, spark plugs, filters, chains, tires, winch ropes etc. and service.
13. To secure warranty service, the purchaser must (1) Report the product defect to an authorized Distributor/Dealer and request repair within the applicable warranty term, (2) Present evidence of the warranty start date, and (3) Make the equipment available to an authorized Distributor/Dealer or service center within a reasonable period of time.
14. Every Distributor/Dealer must ensure that the Product is registered by the Customer on [www.slope-mower.com/machine-registration/](http://www.slope-mower.com/machine-registration/) within seven (7) days after delivery in order to receive the full warranty of 24 months/800 working hours, whichever happens first.
15. All Demo units will be registered by Spider on the date of delivery to the Distributor/Dealer. All Demo units will be appointed by Spider.

In Pohled, April, 2020