

# **WORX**

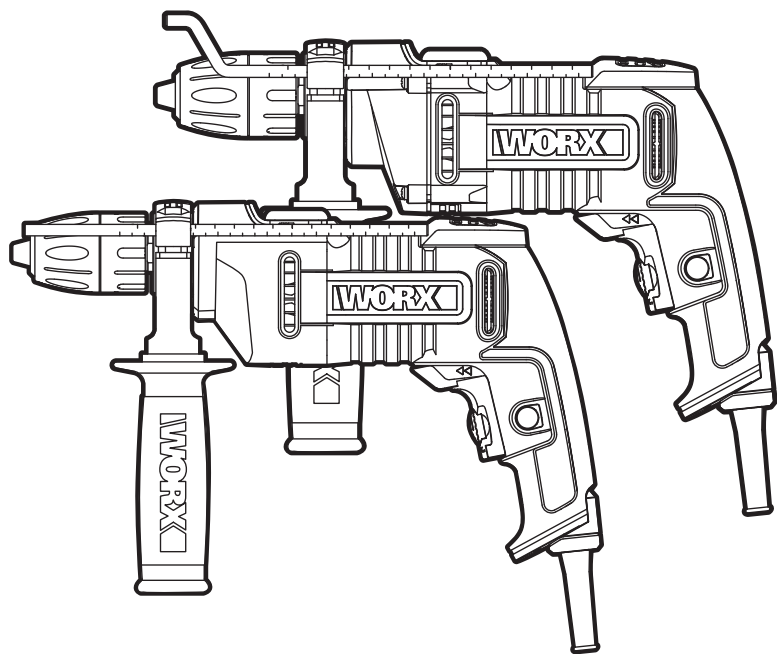

## **SAFETY AND OPERATING MANUAL**

**Impact drill**

**WX317 WX318**

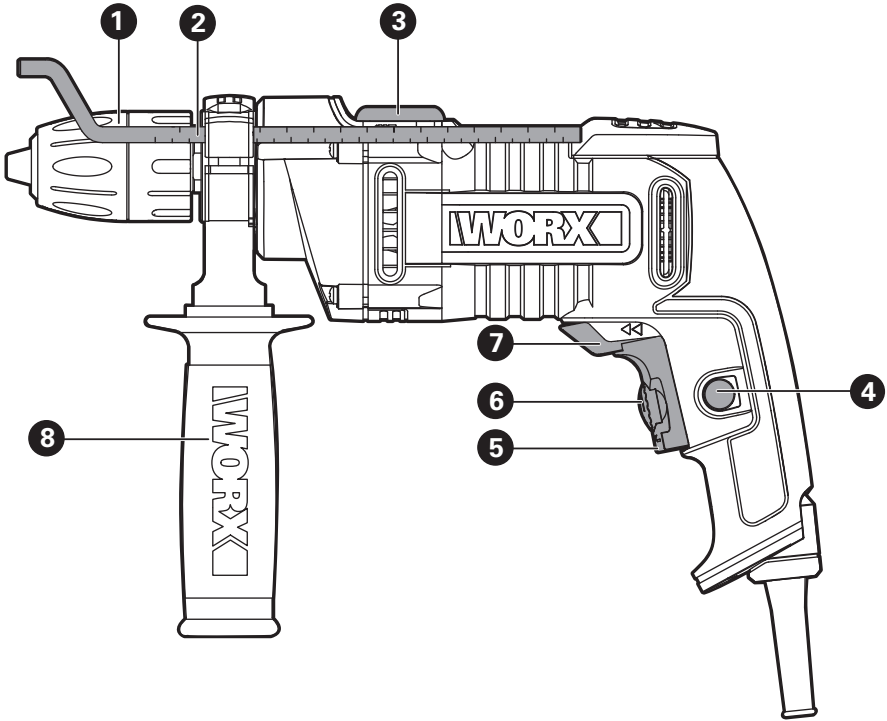

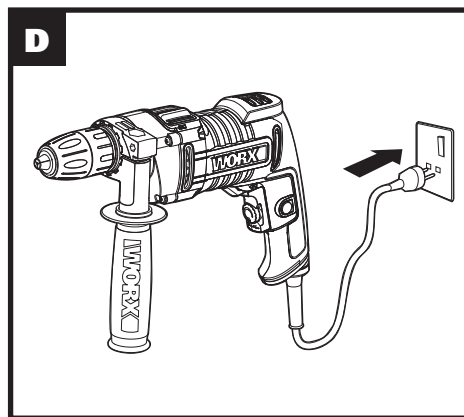
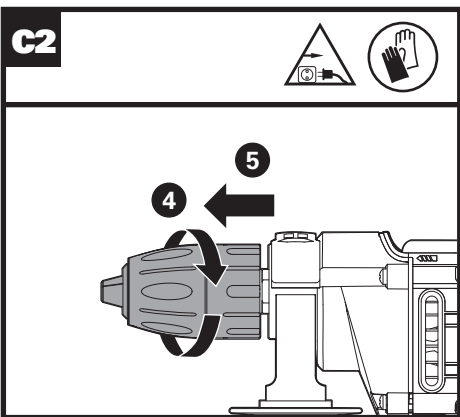
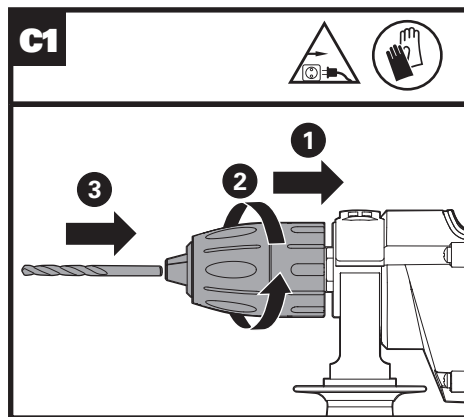
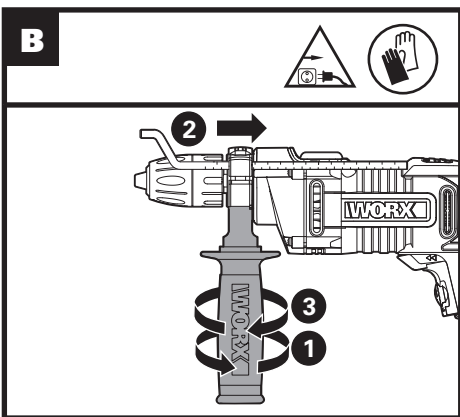
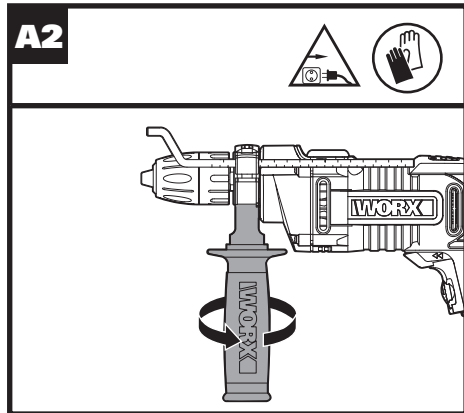
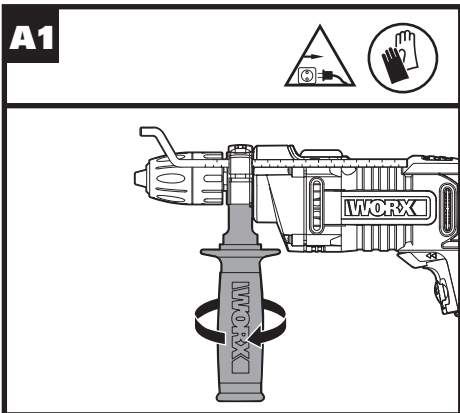

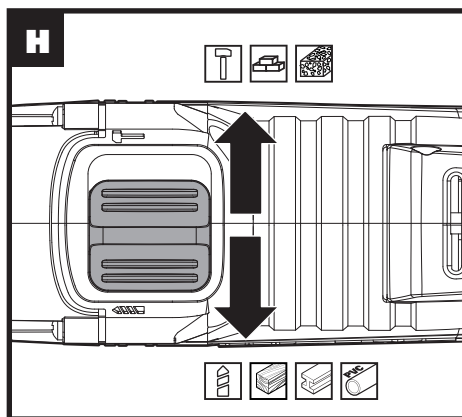
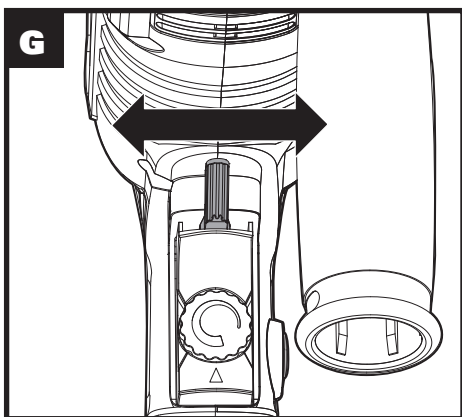
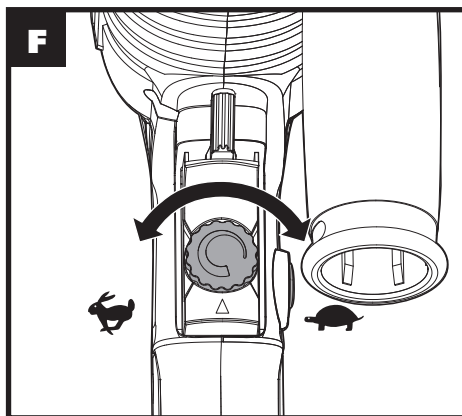
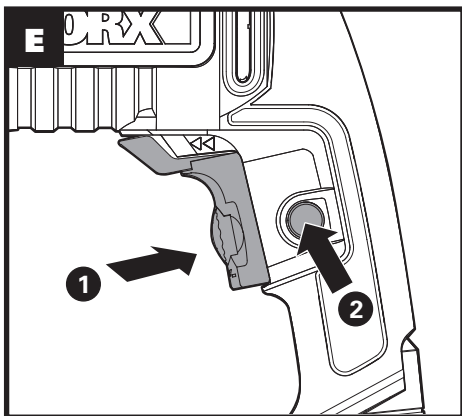

1. **KEYLESS CHUCK**
2. **DEPTH GAUGE**
3. **DRILL/HAMMER DRILL FUNCTION SELECTOR**
4. **SWITCH LOCK ON BUTTON**
5. **ON/OFF SWITCH**
6. **VARIABLE SPEED CONTROL**
7. **FORWARD AND REVERSE ROTATION CONTROL LEVER**
8. **AUXILIARY HANDLE**

Not all the accessories illustrated or described are included in standard delivery.

## TECHNICAL DATA

Type **WX317 WX318 (300-329-designation of machinery, representative of Impact Drill)**

		WX317	WX318
Voltage		230-240V~50Hz	
Power input		600W	810W
No load speed		0-3000/min	
Impact rate		0-48000/min	
Chuck capacity		13mm	
Drilling capacity	Masonry	13mm	16 mm
	Wood	25mm	32 mm
	Steel	13mm	13 mm
Protection class		<input type="checkbox"/> II	
Machine weight		1.6kg	2.42kg

## ACCESSORIES

	WX317	WX318
Auxiliary handle	1	1
Depth gauge	1	1
HSS drill bit	/	3 (5mm, 6mm, 8mm)
Masonry drill bit	/	3 (6mm, 8mm, 10mm)

We recommend that you purchase your accessories from the same store that sold you the tool. Use good quality accessories marked with a well-known brand

name. Choose the type according to the work you intend to undertake. Refer to the accessory packaging for further details. Store personnel can assist you and offer advice.

## ORIGINAL INSTRUCTIONS GENERAL POWER TOOL SAFETY WARNINGS

**!** **WARNING: Read all safety warnings and all instructions.** Failure to follow the warnings and instructions may result in electric shock, fire and/or serious injury. **Save all warnings and instructions for future reference.**

### 1. WORK AREA SAFETY

- a) **Keep work area clean and well lit.** Cluttered or dark areas invite accidents.
- b) **Do not operate power tools in explosive atmospheres, such as in the presence of flammable liquids, gases or dust.** Power tools create sparks which may ignite the dust or fumes.
- c) **Keep children and bystanders away while operating a power tool.** Distractions can cause you to lose control.

### 2. ELECTRICAL SAFETY

- a) **Power tool plugs must match the outlet. Never modify the plug in any way. Do not use any adapter plugs with earthed (grounded) power tools.** Unmodified plugs and matching outlets will reduce risk of electric shock.
- b) **Avoid body contact with earthed or grounded surfaces, such as pipes, radiators, ranges and refrigerators.** There is an increased risk of electric shock if your body is earthed or grounded.
- c) **Do not expose power tools to rain or wet conditions.** Water entering a power tool will increase the risk of electric shock.
- d) **Do not abuse the cord. Never use the cord for carrying, pulling or unplugging the power tool. Keep cord away from heat, oil, sharp edges or moving parts.** Damaged or entangled cords increase the risk of electric shock.
- e) **When operating a power tool outdoors, use an extension cord suitable for outdoor use.** Use of a cord suitable for outdoor use reduces the risk of electric shock.
- f) **If operating a power tool in a damp location is unavoidable, use a residual current device (RCD) protected supply.** Use of an RCD reduces the risk of electric shock.

### 3. PERSONAL SAFETY

- a) **Stay alert, watch what you are doing and use common sense when operating a power tool. Do not use a power tool while you are tired or under the influence of drugs, alcohol or medication.** A moment of inattention while operating power tools may

result in serious personal injury.

- b) Use personal protective equipment. Always wear eye protection.** Protective equipment such as dust mask, non-skid safety shoes, hard hat, or hearing protection used for appropriate conditions will reduce personal injuries.
- c) Prevent unintentional starting. Ensure the switch is in the off-position before connecting to power source and/or battery pack, picking up or carrying the tool.** Carrying power tools with your finger on the switch or energising power tools that have the switch on invites accidents.
- d) Remove any adjusting key or wrench before turning the power tool on.** A wrench or a key left attached to a rotating part of the power tool may result in personal injury.
- e) Do not overreach. Keep proper footing and balance at all times.** This enables better control of the power tool in unexpected situations.
- f) Dress properly. Do not wear loose clothing or jewellery. Keep your hair, clothing and gloves away from moving parts.** Loose clothes, jewellery or long hair can be caught in moving parts.
- g) If devices are provided for the connection of dust extraction and collection facilities, ensure these are connected and properly used.** Use of dust collection can reduce dust-related hazards.

#### 4. POWER TOOL USE AND CARE

- a) Do not force the power tool. Use the correct power tool for your application.** The correct power tool will do the job better and safer at the rate for which it was designed.
- b) Do not use the power tool if the switch does not turn it on and off.** Any power tool that cannot be controlled with the switch is dangerous and must be repaired.
- c) Disconnect the plug from the power source and/or the battery pack from the power tool before making any adjustments, changing accessories, or storing power tools.** Such preventive safety measures reduce the risk of starting the power tool accidentally.
- d) Store idle power tools out of the reach of children and do not allow persons unfamiliar with the power tool or these instructions to operate the power tool.** Power tools are dangerous in the hands of untrained users.
- e) Maintain power tools. Check for misalignment or binding of moving parts, breakage of parts and any other condition that may affect the power tool's operation. If damaged, have the power tool repaired before use.** Many accidents are caused by poorly maintained power tools.
- f) Keep cutting tools sharp and clean.** Properly maintained cutting tools with sharp cutting edges are less likely to bind and are easier to control.
- g) Use the power tool, accessories and tool bits etc. in accordance with these**

**instructions, taking into account the working conditions and the work to be performed.** Use of the power tool for operations different from those intended could result in a hazardous situation.







#### 5. SERVICE









- a) Have your power tool serviced by a qualified repair person using only identical replacement parts.** This will ensure that the safety of the power tool is maintained.

## ADDITIONAL SAFETY POINTS FOR YOUR DRILL & IMPACT DRILL

- 1. Wear ear protectors when impact drilling.** Exposure to noise can cause hearing loss.
- 2. Use auxiliary handle(s), if supplied with the tool.** Loss of control can cause personal injury.
- 3. Hold power tool by insulated gripping surfaces, when performing an operation where the cutting accessory may contact hidden wiring or its own cord.** Cutting accessory contacting a "live" wire may make exposed metal parts of the power tool "live" and could give the operator an electric shock.

## SYMBOLS

	To reduce the risk of injury, user must read instruction manual
	Double insulation
	Wear ear protection
	Wear eye protection
	Wear dust mask
	Before any work on the machine itself, pull the mains plug from the socket outlet.
	Wear protective gloves
	RCM marking

	Hammer drilling
	Drilling
	Wood
	Metal
	Plastic
	Concrete
	Masonry
	High speed
	Low speed
<b>ABN</b>	Australian Business Number. By this number, business information such as entity type, status, business location etc. can be found at website <a href="http://abr.business.gov.au">http://abr.business.gov.au</a> . ABN of Positec Australia Pty Limited is 14 101 682 357

## OPERATING INSTRUCTIONS



**NOTE:** Before using the tool, read the instruction book carefully.

Recommendation that the tool always be supplied via a residual current device with a rated residual current of 30 mA or less

### INTENDED USE

The machine is intended for impact drilling in brick, concrete and stone as well as for drilling in wood, metal and plastic.

## ASSEMBLY AND OPERATION

ACTION	FIGURE
Clamping and loosening the Auxiliary Handle  <b>WARNING!</b> Always check and rotate the handle tightly before using to avoid any accident.	See Fig. A1, A2
Installing the Depth Gauge	See Fig. B
Inserting Bits into Chuck	See Fig. C1, C2
Plugging in the power	See Fig. D
On/Off Switch and Lock-on Button	See Fig. E
Variable Speed Control	See Fig. F
Forward and Reverse Rotation Control <b>NOTE: Never move the forward/reverse switch whilst the drill in operation or the on/off switch is locked as this will damage the drill.</b>	See Fig. G
Hammer or Drilling Control	See Fig. H

## WORKING HINTS FOR YOUR DRILL

### 1. Drilling masonry and concrete

Select the drill/impact action selector switch to the “hammer symbol” position. Tungsten carbide drill bits should always be used for drilling masonry, concrete etc with a high speed.

### 2. Drilling steel

Select the drill/impact action selector switch to the “drill symbol” position. HSS drill bits should always be used for drilling steel with a lower speed.

### 3. Pilot holes

When drilling a large hole in tough material (i.e. steel), we recommend drilling a small pilot hole first before using a large drill bit.

### 4. Drilling tiles

Select the drill/impact action selector switch to the “drill symbol” position to drill the tile. When tile has been penetrated, switch over to “hammer symbol” position.

### 5. Cool the motor

If your power tool becomes too hot, set the speed to maximum and run no load for 2-3 minutes to cool the motor.

# MAINTENANCE

**Remove the plug from the socket before carrying out any adjustment, servicing or maintenance.**

Your power tool requires no additional lubrication or maintenance.

There are no user serviceable parts in your power tool. Never use water or chemical cleaners to clean your power tool. Wipe clean with a dry cloth. Always store your power tool in a dry place. Keep the motor ventilation slots clean. Keep all working controls free of dust. Occasionally you may see sparks through the ventilation slots. This is normal and will not damage your power tool.

If the supply cord is damaged, it must be replaced by the manufacturer, its service agent or similarly qualified persons in order to avoid a hazard.

If the replacement of the supply cord is necessary, this has to be done by the manufacturer or his agent in order to avoid a safety hazard.

# TROUBLESHOOTING

1. If your power tool does not start, check the plug on the power supply first.
2. If the drill doesn't work properly, check the drill bit for sharpness, replace drill bit if worn. Check that the drill is set to forward rotation for normal use.
3. If a fault can not be rectified, return the tool to an authorized dealer for repair



**[www.worx.com](http://www.worx.com)**

Copyright © 2015, Positec. All Rights Reserved.  
AR01018601