



# HOSHIZAKI

# KM-60C-HC

## Crescent 52kg Ice Maker - Self Contained

## PRODUCT FEATURES

- Individual premium crescent cube with no ice bridging.
- Exceptionally hard crystal clear cubes that melt slowly.
- Durable stainless steel exterior.
- Slide in air filter at front for easy cleaning -maintaining performance efficiency.
- Double-sided stainless steel evaporator for all water conditions -produces more ice in less cycles.
- Flush mount to rear wall.
- Good in hard water areas.
- Snap in water tank design – easy to remove for sanitization.
- Low electrical consumption.
- Low water consumption.
- LED lights and audible alarms.



## TECHNICAL DRAWING

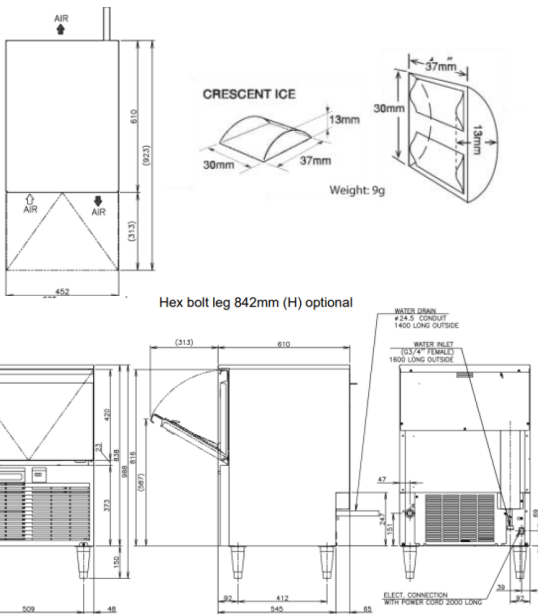

## PRODUCT SPECIFICATION

|                              |  |
|------------------------------|--|
| Production Capacity / 24hrs  | Approx. 52kg @ 21°C Air temp; 15°C Water<br>Approx. 37kg @ 32°C Air temp; 21°C Water |
| Max Storage Capacity         | Approx. 23kg   |
| Dimensions                   | 605mm (W) x 610mm (D) x 988mm (H)<br>(Includes 982mm-1005mm Legs)                    |
| Cooling                      | Air  |
| Weight Net/Gross (kg)        | 45/57  |
| Refrigerant Charge           | R290/90g   |
| AC Supply Voltage            | 1 PHASE 220-240V 50Hz/ 10 AMP Plug   |
| Amperage                     | Running: 1.6A Starting: 8.5A   |
| <b>Operating Conditions:</b> |  |
| Ambient Temp                 | 7-38°C   |
| Water Supply Temp            | 7-32°C   |
| Water Supply Pressure        | 0.07-0.8MPa (0.7-8bar)   |
| Voltage Range                | ±6%  |

## INSTALLATION REQUIREMENTS

- Ensure the condenser is cleaned periodically as per the manufacturer's manual.
- Do not plug the unit into multi-plug power boards with other appliances
- Room ventilation or air conditioning can improve the situation by reducing the humidity.
- Hoshizaki recommends the use of a compatible water filter to prevent non-warrantable scale & sediment complications.

\*Refer to manual for full installation & maintenance requirements.



For free 6 month extended warranty, register online within 4 weeks of purchase date.  
[hoshizaki.com.au](http://hoshizaki.com.au)

